

Алматы (7273)495-231
 Ангарск (3955)60-70-56
 Архангельск (8182)63-90-72
 Астрахань (8512)99-46-04
 Барнаул (3852)73-04-60
 Белгород (4722)40-23-64
 Благовещенск (4162)22-76-07
 Брянск (4832)59-03-52
 Владивосток (423)249-28-31
 Владикавказ (8672)28-90-48
 Владимир (4922)49-43-18
 Волгоград (844)278-03-48
 Вологда (8172)26-41-59
 Воронеж (473)204-51-73
 Екатеринбург (343)384-55-89

Иваново (4932)77-34-06
 Ижевск (3412)26-03-58
 Иркутск (395)279-98-46
 Казань (843)206-01-48
 Калининград (4012)72-03-81
 Калуга (4842)92-23-67
 Кемерово (3842)65-04-62
 Киров (8332)68-02-04
 Коломна (4966)23-41-49
 Кострома (4942)77-07-48
 Краснодар (861)203-40-90
 Красноярск (391)204-63-61
 Курск (4712)77-13-04
 Курган (3522)50-90-47
 Липецк (4742)52-20-81

Магнитогорск (3519)55-03-13
 Москва (495)268-04-70
 Ижевск (3412)26-03-58
 Мурманск (8152)59-64-93
 Набережные Челны (8552)20-53-41
 Нижний Новгород (831)429-08-12
 Новокузнецк (3843)20-46-81
 Ноябрьск (3496)41-32-12
 Новосибирск (383)227-86-73
 Омск (3812)21-46-40
 Орел (4862)44-53-42
 Оренбург (3532)37-68-04
 Пенза (8412)22-31-16
 Петрозаводск (8142)55-98-37
 Псков (8112)59-10-37
 Пермь (342)205-81-47

Ростов-на-Дону (863)308-18-15
 Рязань (4912)46-61-64
 Самара (846)206-03-16
 Санкт-Петербург (812)309-46-40
 Саратов (845)249-38-78
 Севастополь (8692)22-31-93
 Саранск (8342)22-96-24
 Симферополь (3652)67-13-56
 Смоленск (4812)29-41-54
 Сочи (862)225-72-31
 Ставрополь (8652)20-65-13
 Сургут (3462)77-98-35
 Сыктывкар (8212)25-95-17
 Тамбов (4752)50-40-97
 Тверь (4822)63-31-35

Тольятти (8482)63-91-07
 Томск (3822)98-41-53
 Тула (4872)33-79-87
 Тюмень (3452)66-21-18
 Ульяновск (8422)24-23-59
 Улан-Удэ (3012)59-97-51
 Уфа (347)229-48-12
 Хабаровск (4212)92-98-04
 Чебоксары (8352)28-53-07
 Челябинск (351)202-03-61
 Череповец (8202)49-02-64
 Чита (3022)38-34-83
 Якутск (4112)23-90-97
 Ярославль (4852)69-52-93

Россия +7(495)268-04-70

Казахстан +7(7172)727-132

Киргизия +996(312)96-26-47

<https://kastas.nt-rt.ru/> || ksi@nt-rt.ru

K75 - PISTON-ROD GUIDE RING



K75 piston-rod guide rings are composite guiding elements, produced from syntetic fabric and phenolic resin which provides high load carrying capacity designed to be used in rod and piston applications in hydraulic systems.

Advantages

- Low coefficient of friction
- High Load bearing capacity
- The high form stability at operating temperature range
- Low swelling
- Wide range of dimensions

Area of Application

- Mobile machinery
- Mining industry
- Excavators
- Presses
- Heavy duty cylinders

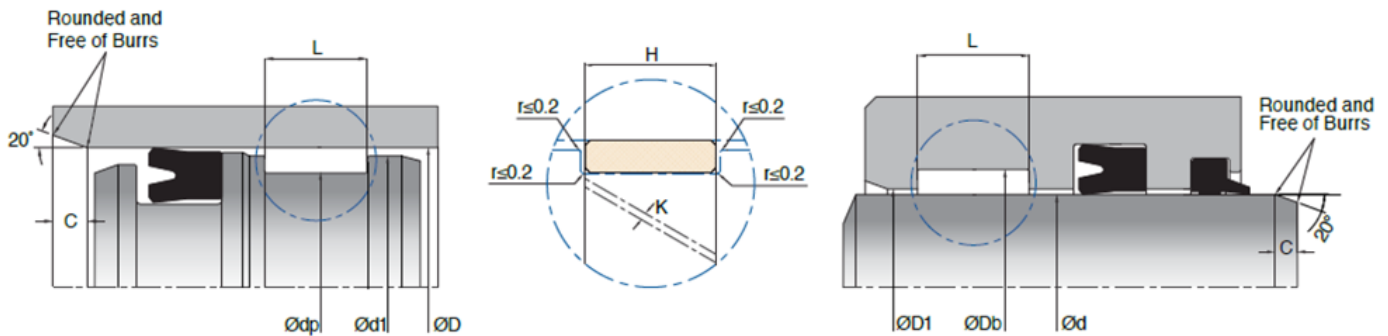

	d(f8) dp(h8)	Db(H8) D(H9)	L (+0.2/- 0)	H	d1 (h9)	D1 (H9)	MATERIAL	Kastaş CODE
K75-025	25	30	9.7	9.5	28.2	26.8	PH6501	20000906
K75-030	30	35	9.7	9.5	33.2	31.8	PH6501	20000908
K75-035	35	40	15	14.8	38.2	36.8	PH6501	20000909
K75-035/1	35	40	9.7	9.5	38.2	36.8	PH6501	20000910
K75-036	36	40	10	9.8	39	37	PH6501	20000911
K75-040/1	40	45	9.7	9.5	43.2	41.8	PH6501	20000913
K75-040/2	40	45	15	14.8	43.2	41.8	PH6501	20000914
K75-040/3	40	44	15	14.8	43	41	PH6501	20000915
K75-045	45	50	9.7	9.5	48.2	46.8	PH6501	20000916
K75-045/1	45	50	15	14.8	48.2	46.8	PH6501	20000917
K75-050	50	55	9.7	9.5	53.2	51.8	PH6501	20000918
K75-050/1	50	55	15	14.8	53.2	51.8	PH6501	20000919
K75-050/2	50	54	10	9.8	53	51	PH6501	20000920
K75-055	55	60	15	14.8	58.2	56.8	PH6501	20000921
K75-055/1	55	60	9.7	9.5	58.2	56.8	PH6501	20000922
K75-056	56	62	8.1	7.9	59.6	58.4	PH6501	20000923
K75-056/1	56	62	12.5	12.3	59.6	58.4	PH6501	20000924
K75-056/2	56	62	20	19.8	59.6	58.4	PH6501	20000925
K75-056/3	56	61	15	14.8	59.2	57.8	PH6501	20000926
K75-058	58	63	9.7	9.5	61.2	59.8	PH6501	20000927
K75-060	60	65	15	14.8	63.2	61.8	PH6501	20000928
K75-060/1	60	65	9.7	9.5	63.2	61.8	PH6501	20000929
K75-060/2	60	65	20	19.8	63.2	61.8	PH6501	20000930
K75-063	63	68	15	14.8	66.2	64.8	PH6501	20000931
K75-063/1	63	68	9.7	9.5	66.2	64.8	PH6501	20000933
K75-063.5/1	63.5	66.54	6.2	6	65.54	64.5	PH6501	20000932
K75-065	65	70	15	14.8	68.2	66.8	PH6501	20000934
K75-065/1	65	70	9.7	9.5	68.2	66.8	PH6501	20000935
K75-070	70	75	9.7	9.5	73.2	71.8	PH6501	20000936
K75-070/1	70	75	15	14.8	73.2	71.8	PH6501	20000937
K75-070/2	70	75	20	19.8	73.2	71.8	PH6501	20000938
K75-074	74	80	6.5	6.3	77.6	76.4	PH6501	20000939
K75-075	75	80	9.7	9.5	78.2	76.8	PH6501	20000940
K75-075/1	75	80	15	14.8	78.2	76.8	PH6501	20000941
K75-080	80	85	9.7	9.5	83.2	81.8	PH6501	20000942
K75-080/1	80	85	15	14.8	83.2	81.8	PH6501	20000943

	d(f8) dp(h8)	Db(H8) D(H9)	L (+0.2/- 0)	H	d1 (h9)	D1 (H9)	MATERIAL	Kastaş CODE
K75-080/2	80	85	20	19.8	83.2	81.8	PH6501	20000944
K75-080/3	80	86	30	29.8	83.6	82.4	PH6501	20000945
K75-084	84	90	6.5	6.3	87.6	86.4	PH6501	20000946
K75-085	85	90	9.7	9.5	88.2	86.8	PH6501	20000947
K75-085/1	85	90	15	14.8	88.2	86.8	PH6501	20000948
K75-085/2	85	90	25	24.8	88.2	86.8	PH6501	20000949
K75-085/3	85	90	20	19.8	88.2	86.8	PH6501	20000950
K75-090	90	95	15	14.8	93.2	91.8	PH6501	20000951
K75-090/1	90	95	9.7	9.5	93.2	91.8	PH6501	20000952
K75-090/2	90	95	5.6	5.4	93.2	91.8	PH6501	20000953
K75-094	94	100	6.5	6.3	97.6	96.4	PH6501	20000954
K75-095	95	100	9.7	9.5	98.2	96.8	PH6501	20000955
K75-095/1	95	100	15	14.8	98.2	96.8	PH6501	20000956
K75-095/2	95	100	20	19.8	98.2	96.8	PH6501	20000957
K75-100	100	105	15	14.8	103.2	101.8	PH6501	20000958
K75-100/1	100	105	9.7	9.5	103.2	101.8	PH6501	20000959
K75-100/2	100	105	20	19.8	103.2	101.8	PH6501	20000960
K75-100/3	100	105	25	24.8	103.2	101.8	PH6501	20000961
K75-105	105	110	9.7	9.5	108.2	106.8	PH6501	20000965
K75-105/1	105	110	15	14.8	108.2	106.8	PH6501	20000966
K75-105/2	105	110	5.6	5.4	108.2	106.8	PH6501	20000967
K75-105/3	105	110	20	19.8	108.2	106.8	PH6501	20000968
K75-109	109	115	6.5	6.3	112.6	111.4	PH6501	20000970
K75-110	110	115	9.7	9.5	113.2	111.8	PH6501	20000971
K75-110/1	110	115	15	14.8	113.2	111.8	PH6501	20000972
K75-110/2	110	115	5.6	5.4	113.2	111.8	PH6501	20000973
K75-113	113	118	15	14.8	116.2	114.8	PH6501	20000974
K75-115	115	120	9.7	9.5	118.2	116.8	PH6501	20000975
K75-115/1	115	120	15	14.8	118.2	116.8	PH6501	20000976
K75-115/2	115	120	25	24.8	118.2	116.8	PH6501	20000977
K75-119	119	125	25	24.8	122.6	121.4	PH6501	20000978
K75-120	120	125	9.7	9.5	123.2	121.8	PH6501	20000979
K75-120/1	120	125	15	14.8	123.2	121.8	PH6501	20000980
K75-120/2	120	125	20	19.8	123.2	121.8	PH6501	20000981
K75-120/3	120	125	25	24.8	123.2	121.8	PH6501	20000982
K75-121	121	126	9.7	9.5	124.2	122.8	PH6501	20000984

	d(f8) dp(h8)	Db(H8) D(H9)	L (+0.2/- 0)	H	d1 (h9)	D1 (H9)	MATERIAL	Kastaş CODE
K75-125	125	130	9.7	9.5	128.2	126.8	PH6501	20000985
K75-125/1	125	130	15	14.8	128.2	126.8	PH6501	20000986
K75-130	130	135	9.7	9.5	133.2	131.8	PH6501	20000988
K75-130/1	130	135	15	14.8	133.2	131.8	PH6501	20000989
K75-130/2	130	135	25	24.8	133.2	131.8	PH6501	20000990
K75-135	135	140	9.7	9.5	138.2	136.8	PH6501	20000991
K75-135/1	135	140	15	14.8	138.2	136.8	PH6501	20000992
K75-135/2	135	140	20	19.8	138.2	136.8	PH6501	20000993
K75-140	140	145	9.7	9.5	143.2	141.8	PH6501	20000995
K75-140/1	140	145	15	14.8	143.2	141.8	PH6501	20000996
K75-140/2	140	148	25	24.8	145	143	PH6501	20000997
K75-142	142	147	15	14.8	145.2	143.8	PH6501	20000998
K75-142/1	142	147	9.7	9.5	145.2	143.8	PH6501	20000999
K75-143	143	150	20	19.8	147	146	PH6501	20001000
K75-145	145	150	9.7	9.5	148.2	146.8	PH6501	20001001
K75-145/1	145	150	15	14.8	148.2	146.8	PH6501	20001002
K75-145/2	145	150	25	24.8	148.2	146.8	PH6501	20001003
K75-148	148	160	15	14.8	157	151	PH6501	20001004
K75-150	150	155	15	14.8	153.2	151.8	PH6501	20001005
K75-150/1	150	155	9.7	9.5	153.2	151.8	PH6501	20001006
K75-155	155	160	9.7	9.5	158.2	156.8	PH6501	20001008
K75-155/1	155	160	15	14.8	158.2	156.8	PH6501	20001009
K75-155/2	155	163	25	24.8	160	158	PH6501	20001010
K75-155/3	155	160	20	19.8	158.2	156.8	PH6501	20001011
K75-160	160	165	20	19.8	163.2	161.8	PH6501	20001012
K75-160/1	160	165	15	14.8	163.2	161.8	PH6501	20001013
K75-165	165	170	9.7	9.5	168.2	166.8	PH6501	20001014
K75-175	175	180	9.7	9.5	178.2	176.8	PH6501	20001015
K75-175/1	175	180	15	14.8	178.2	176.8	PH6501	20001016
K75-175/3	175	180	5.6	5.4	178.2	176.8	PH6501	20001018
K75-178	178	186	20	19.8	183	181	PH6501	20001019
K75-178/1	178	186	9.7	9.5	183	181	PH6501	20001020
K75-180	180	185	15	14.8	183.2	181.8	PH6501	20001021
K75-180/1	180	188	25	24.8	185	183	PH6501	20001022
K75-180/2	180	185	20	19.8	183.2	181.8	PH6501	20001023
K75-182	182	190	25	24.8	187	185	PH6501	20001024

	d(f8) dp(h8)	Db(H8) D(H9)	L (+0.2/- 0)	H	d1 (h9)	D1 (H9)	MATERIAL	Kastaş CODE
K75-185	185	190	9.7	9.5	188.2	186.8	PH6501	20001025
K75-185/1	185	190	15	14.8	188.2	186.8	PH6501	20001026
K75-185/2	185	193	25	24.8	190	188	PH6501	20001027
K75-192	192	200	25	24.8	197	195	PH6501	20001028
K75-192/1	192	197	15	14.8	195.2	193.8	PH6501	20001029
K75-195	195	200	9.7	9.5	198.2	196.8	PH6501	20001031
K75-195/1	195	200	15	14.8	198.2	196.8	PH6501	20001032
K75-195/3	195	200	25	24.8	198.2	196.8	PH6501	20001034
K75-200	200	205	15	14.8	203.2	201.8	PH6501	20001035
K75-200/1	200	208	25	24.8	205	203	PH6501	20001036
K75-205	205	210	25	24.8	208.2	206.8	PH6501	20001037
K75-205/1	205	210	9.7	9.5	208.2	206.8	PH6501	20001038
K75-210	210	218	25	24.8	215	213	PH6501	20001039
K75-212	212	220	25	24.8	217	215	PH6501	20001040
K75-215	215	220	15	14.8	218.2	216.8	PH6501	20001041
K75-217	217	225	25	24.8	222	220	PH6501	20001042
K75-225	225	230	15	14.8	228.2	226.8	PH6501	20001043
K75-235	235	240	25	24.8	238.2	236.8	PH6501	20001045
K75-240	240	245	15	14.8	243.2	241.8	PH6501	20001046
K75-240/1	240	248	25	24.8	245	243	PH6501	20001047
K75-242	242	250	25	24.8	247	245	PH6501	20001048
K75-245	245	250	9.7	9.5	248.2	246.8	PH6501	20001049
K75-245/1	245	250	15	14.8	248.2	246.8	PH6501	20001050
K75-245/2	245	250	25	24.8	248.2	246.8	PH6501	20001051
K75-250	250	258	25	24.8	255	253	PH6501	20001052
K75-260	260	268	25	24.8	265	263	PH6501	20001053
K75-260/1	260	265	25	24.8	263.2	261.8	PH6501	20001054
K75-265	265	270	15	14.8	268.2	266.8	PH6501	20001055
K75-275	275	280	9.7	9.5	278.2	276.8	PH6501	20001056
K75-275/1	275	280	25	24.8	278.2	276.8	PH6501	20001057
K75-285	285	290	25	24.8	288.2	286.8	PH6501	20001058
K75-290	290	298	25	24.8	295	293	PH6501	20001059
K75-292	292	300	25	24.8	297	295	PH6501	20001060
K75-295	295	300	15	14.8	298.2	296.8	PH6501	20001061
K75-300	300	308	25	24.8	305	303	PH6501	20001062
K75-342	342	350	25	24.8	347	345	PH6501	20001065

	d(f8) dp(h8)	Db(H8) D(H9)	L (+0.2/- 0)	H	d1 (h9)	D1 (H9)	MATERIAL	Kastaş CODE
K75-345	345	350	25	24.8	348.2	346.8	PH6501	20001066
K75-345/1	345	350	15	14.8	348.2	346.8	PH6501	20001067
K75-360	360	365	25	24.8	363.2	361.8	PH6501	20001068
K75-392	392	400	25	24.8	397	395	PH6501	20001069

Алматы (7273)495-231
Ангарск (3955)60-70-56
Архангельск (8182)63-90-72
Астрахань (8512)99-46-04
Барнаул (3852)73-04-60
Белгород (4722)40-23-64
Благовещенск (4162)22-76-07
Брянск (4832)59-03-52
Владивосток (423)249-28-31
Владикавказ (8672)28-90-48
Владимир (4922)49-43-18
Волгоград (844)278-03-48
Вологда (8172)26-41-59
Воронеж (473)204-51-73
Екатеринбург (343)384-55-89

Иваново (4932)77-34-06
Ижевск (3412)26-03-58
Иркутск (395)279-98-46
Казань (843)206-01-48
Калининград (4012)72-03-81
Калуга (4842)92-23-67
Кемерово (3842)65-04-62
Киров (8332)68-02-04
Коломна (4966)23-41-49
Кострома (4942)77-07-48
Краснодар (861)203-40-90
Красноярск (391)204-63-61
Курск (4712)77-13-04
Курган (3522)50-90-47
Липецк (4742)52-20-81

Магнитогорск (3519)55-03-13
Москва (495)268-04-70
Мурманск (8152)59-64-93
Набережные Челны (8552)20-53-41
Нижний Новгород (831)429-08-12
Новокузнецк (3843)20-46-81
Ноябрьск (3496)41-32-12
Новосибирск (383)227-86-73
Омск (3812)21-46-40
Орел (4862)44-53-42
Оренбург (3532)37-68-04
Пенза (8412)22-31-16
Петрозаводск (8142)55-98-37
Псков (8112)59-10-37
Пермь (342)205-81-47

Ростов-на-Дону (863)308-18-15
Рязань (4912)46-61-64
Самара (846)206-03-16
Санкт-Петербург (812)309-46-40
Саратов (845)249-38-78
Севастополь (8692)22-31-93
Саранск (8342)22-96-24
Симферополь (3652)67-13-56
Смоленск (4812)29-41-54
Сочи (862)225-72-31
Ставрополь (8652)20-65-13
Сургут (3462)77-98-35
Сыктывкар (8212)25-95-17
Тамбов (4752)50-40-97
Тверь (4822)63-31-35

Тольятти (8482)63-91-07
Томск (3822)98-41-53
Тула (4872)33-79-87
Тюмень (3452)66-21-18
Ульяновск (8422)24-23-59
Улан-Удэ (3012)59-97-51
Уфа (347)229-48-12
Хабаровск (4212)92-98-04
Чебоксары (8352)28-53-07
Челябинск (351)202-03-61
Череповец (8202)49-02-64
Чита (3022)38-34-83
Якутск (4112)23-90-97
Ярославль (4852)69-52-93

Россия +7(495)268-04-70

Казахстан +7(7172)727-132

Киргизия +996(312)96-26-47

<https://kastas.nt-rt.ru/> || ksi@nt-rt.ru