

Алматы (7273)495-231
 Ангарск (3955)60-70-56
 Архангельск (8182)63-90-72
 Астрахань (8512)99-46-04
 Барнаул (3852)73-04-60
 Белгород (4722)40-23-64
 Благовещенск (4162)22-76-07
 Брянск (4832)59-03-52
 Владивосток (423)249-28-31
 Владикавказ (8672)28-90-48
 Владимир (4922)49-43-18
 Волгоград (844)278-03-48
 Вологда (8172)26-41-59
 Воронеж (473)204-51-73
 Екатеринбург (343)384-55-89

Иваново (4932)77-34-06
 Ижевск (3412)26-03-58
 Иркутск (395)279-98-46
 Казань (843)206-01-48
 Калининград (4012)72-03-81
 Калуга (4842)92-23-67
 Кемерово (3842)65-04-62
 Киров (8332)68-02-04
 Коломна (4966)23-41-49
 Кострома (4942)77-07-48
 Краснодар (861)203-40-90
 Красноярск (391)204-63-61
 Курск (4712)77-13-04
 Курган (3522)50-90-47
 Липецк (4742)52-20-81

Магнитогорск (3519)55-03-13
 Москва (495)268-04-70
 Ижевск (3412)26-03-58
 Мурманск (8152)59-64-93
 Набережные Челны (8552)20-53-41
 Нижний Новгород (831)429-08-12
 Новокузнецк (3843)20-46-81
 Ноябрьск (3496)41-32-12
 Новосибирск (383)227-86-73
 Омск (3812)21-46-40
 Орел (4862)44-53-42
 Оренбург (3532)37-68-04
 Пенза (8412)22-31-16
 Петрозаводск (8142)55-98-37
 Псков (8112)59-10-37
 Пермь (342)205-81-47

Ростов-на-Дону (863)308-18-15
 Рязань (4912)46-61-64
 Самара (846)206-03-16
 Санкт-Петербург (812)309-46-40
 Саратов (845)249-38-78
 Севастополь (8692)22-31-93
 Саранск (8342)22-96-24
 Симферополь (3652)67-13-56
 Смоленск (4812)29-41-54
 Сочи (862)225-72-31
 Ставрополь (8652)20-65-13
 Сургут (3462)77-98-35
 Сыктывкар (8212)25-95-17
 Тамбов (4752)50-40-97
 Тверь (4822)63-31-35

Тольятти (8482)63-91-07
 Томск (3822)98-41-53
 Тула (4872)33-79-87
 Тюмень (3452)66-21-18
 Ульяновск (8422)24-23-59
 Улан-Удэ (3012)59-97-51
 Уфа (347)229-48-12
 Хабаровск (4212)92-98-04
 Чебоксары (8352)28-53-07
 Челябинск (351)202-03-61
 Череповец (8202)49-02-64
 Чита (3022)38-34-83
 Якутск (4112)23-90-97
 Ярославль (4852)69-52-93

Россия +7(495)268-04-70

Казахстан +7(7172)727-132

Киргизия +996(312)96-26-47

<https://kastas.nt-rt.ru/> || ksi@nt-rt.ru

K780 - ROD GUIDE RING



K780 is a composite bushing consists of carbon steel, bronze, and PTFE. K780 is a self-lubricating bushing which provides low friction and low abrasion.

Advantages

- Suitable for dry applications
- Abrasion Resistance
- Low friction
- Long service life
- Good thermal properties and dimensional stability
- Optimum oil film
- Superior load bearing capacity

Area of Application

- Hydraulic and Pneumatic Cylinders
- Applications with high radial load

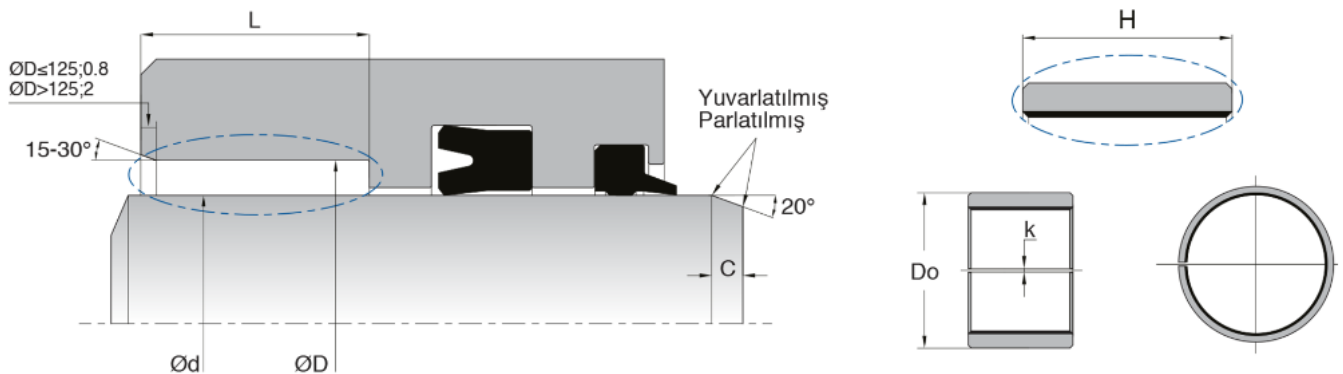

	d (f7)	D (H7)	L (+0.2/-0)	MATERIAL	Kastaş CODE
K780-006	6	8	10	Çelik - Teflon - Burç	20001083

	d (f7)	D (H7)	L (+0.2/-0)	MATERIAL	Kastaş CODE
K780-008	8	10	10	Çelik - Teflon - Burç	20001084
K780-008/2	8	10	8	Çelik - Teflon - Burç	20001085
K780-010	10	12	15	Çelik - Teflon - Burç	20001086
K780-012	12	14	15	Çelik - Teflon - Burç	20001087
K780-012/1	12	14	20	Çelik - Teflon - Burç	20001088
K780-012/2	12	14	10	Çelik - Teflon - Burç	20001089
K780-016	16	18	15	Çelik - Teflon - Burç	20001090
K780-016/1	16	18	12	Çelik - Teflon - Burç	20001091
K780-017	17	19	20	Çelik - Teflon - Burç	20001092
K780-017/1	17	19	25	Çelik - Teflon - Burç	20001093
K780-020	20	23	15	Çelik - Teflon - Burç	20001094
K780-020/1	20	23	20	Çelik - Teflon - Burç	20001095
K780-020/2	20	23	30	Çelik - Teflon - Burç	20001096
K780-020/4	20	23	25	Çelik - Teflon - Burç	20001097
K780-020/5	20	22	15	Çelik - Teflon - Burç	20001098
K780-022	22	25	26.5	Çelik - Teflon - Burç	20001099
K780-025	25	28	30	Çelik - Teflon - Burç	20001100
K780-025/1	25	28	20	Çelik - Teflon - Burç	20001101
K780-025/2	25	28	25	Çelik - Teflon - Burç	20001102
K780-028	28	32	30	Çelik - Teflon - Burç	20001103
K780-028/1	28	32	25	Çelik - Teflon - Burç	20001104
K780-030	30	34	30	Çelik - Teflon - Burç	20001105
K780-030/1	30	34	20	Çelik - Teflon - Burç	20001106
K780-030/2	30	34	15	Çelik - Teflon - Burç	20001107
K780-032	32	36	40	Çelik - Teflon - Burç	20001108
K780-032/1	32	36	30	Çelik - Teflon - Burç	20001109
K780-035	35	40	60	Çelik - Teflon - Burç	20001110
K780-036	36	40	30	Çelik - Teflon - Burç	20001111
K780-038	38	42	38	Çelik - Teflon - Burç	20001112
K780-040	40	44	20	Çelik - Teflon - Burç	20001113
K780-040/1	40	44	25	Çelik - Teflon - Burç	20001114
K780-040/2	40	44	30	Çelik - Teflon - Burç	20001115
K780-040/3	40	45	30	Çelik - Teflon - Burç	20001116
K780-040/4	40	44	40	Çelik - Teflon - Burç	20001117
K780-040/5	40	45	20	Çelik - Teflon - Burç	20001118
K780-045	45	50	30	Çelik - Teflon - Burç	20001119
K780-045/1	45	50	60	Çelik - Teflon - Burç	20001120

	d (f7)	D (H7)	L (+0.2/-0)	MATERIAL	Kastaş CODE
K780-045/2	45	50	50	Çelik - Teflon - Burç	20001121
K780-050	50	55	30	Çelik - Teflon - Burç	20001123
K780-050/1	50	55	20	Çelik - Teflon - Burç	20001124
K780-050/2	50	55	40	Çelik - Teflon - Burç	20001125
K780-050/3	50	55	50	Çelik - Teflon - Burç	20001126
K780-055	55	60	60	Çelik - Teflon - Burç	20001128
K780-055/1	55	60	30	Çelik - Teflon - Burç	20001129
K780-055/2	55	60	40	Çelik - Teflon - Burç	20001130
K780-060	60	65	20	Çelik - Teflon - Burç	20001131
K780-060/1	60	65	30	Çelik - Teflon - Burç	20001132
K780-060/2	60	65	40	Çelik - Teflon - Burç	20001133
K780-060/3	60	65	50	Çelik - Teflon - Burç	20001134
K780-060/4	60	65	60	Çelik - Teflon - Burç	20001135
K780-065	65	70	50	Çelik - Teflon - Burç	20001136
K780-065/1	65	70	30	Çelik - Teflon - Burç	20001137
K780-065/2	65	70	60	Çelik - Teflon - Burç	20001138
K780-065/3	65	70	40	Çelik - Teflon - Burç	20001139
K780-070	70	75	30	Çelik - Teflon - Burç	20001140
K780-070/1	70	75	40	Çelik - Teflon - Burç	20001141
K780-070/2	70	75	50	Çelik - Teflon - Burç	20001142
K780-070/3	70	75	80	Çelik - Teflon - Burç	20001143
K780-070/4	70	75	35	Çelik - Teflon - Burç	20001144
K780-070/5	70	75	15	Çelik - Teflon - Burç	20001145
K780-075	75	80	30	Çelik - Teflon - Burç	20001146
K780-075/1	75	80	40	Çelik - Teflon - Burç	20001147
K780-075/2	75	80	35	Çelik - Teflon - Burç	20001148
K780-075/3	75	80	60	Çelik - Teflon - Burç	20001149
K780-080	80	85	30	Çelik - Teflon - Burç	20001150
K780-080/1	80	85	40	Çelik - Teflon - Burç	20001151
K780-080/2	80	85	35	Çelik - Teflon - Burç	20001152
K780-080/3	80	85	60	Çelik - Teflon - Burç	20001153
K780-085	85	90	30	Çelik - Teflon - Burç	20001154
K780-085/1	85	90	40	Çelik - Teflon - Burç	20001155
K780-085/2	85	90	35	Çelik - Teflon - Burç	20001156
K780-085/3	85	90	60	Çelik - Teflon - Burç	20001157
K780-090	90	95	30	Çelik - Teflon - Burç	20001158
K780-090/1	90	95	40	Çelik - Teflon - Burç	20001159

	d (f7)	D (H7)	L (+0.2/-0)	MATERIAL	Kastaş CODE
K780-090/2	90	95	20	Çelik - Teflon - Burç	20001160
K780-090/3	90	95	35	Çelik - Teflon - Burç	20001161
K780-090/4	90	95	50	Çelik - Teflon - Burç	20001162
K780-090/5	90	95	60	Çelik - Teflon - Burç	20001163
K780-095	95	100	30	Çelik - Teflon - Burç	20001164
K780-095/1	95	100	40	Çelik - Teflon - Burç	20001165
K780-095/2	95	100	60	Çelik - Teflon - Burç	20001166
K780-095/3	95	100	50	Çelik - Teflon - Burç	20001167
K780-100	100	105	30	Çelik - Teflon - Burç	20001168
K780-100/1	100	105	35	Çelik - Teflon - Burç	20001169
K780-100/2	100	105	50	Çelik - Teflon - Burç	20001170
K780-100/3	100	105	60	Çelik - Teflon - Burç	20001171
K780-100/4	100	105	40	Çelik - Teflon - Burç	20001172
K780-100/5	100	105	20	Çelik - Teflon - Burç	20001173
K780-105	105	110	60	Çelik - Teflon - Burç	20001174
K780-105/1	105	110	50	Çelik - Teflon - Burç	20001175
K780-105/2	105	110	35	Çelik - Teflon - Burç	20001176
K780-105/3	105	110	40	Çelik - Teflon - Burç	20001177
K780-110	110	115	50	Çelik - Teflon - Burç	20001178
K780-110/1	110	115	55	Çelik - Teflon - Burç	20001179
K780-110/2	110	115	35	Çelik - Teflon - Burç	20001180
K780-110/3	110	115	40	Çelik - Teflon - Burç	20001181
K780-110/4	110	115	30	Çelik - Teflon - Burç	20001182
K780-110/5	110	115	60	Çelik - Teflon - Burç	20001183
K780-115	115	120	35	Çelik - Teflon - Burç	20001184
K780-115/1	115	120	60	Çelik - Teflon - Burç	20001185
K780-115/2	115	120	50	Çelik - Teflon - Burç	20001186
K780-115/4	115	120	45	Çelik - Teflon - Burç	20001187
K780-120	120	125	35	Çelik - Teflon - Burç	20001188
K780-120/1	120	125	45	Çelik - Teflon - Burç	20001189
K780-120/2	120	125	20	Çelik - Teflon - Burç	20001190
K780-120/3	120	125	40	Çelik - Teflon - Burç	20001191
K780-120/4	120	125	50	Çelik - Teflon - Burç	20001192
K780-120/5	120	125	60	Çelik - Teflon - Burç	20001193
K780-125	125	130	50	Çelik - Teflon - Burç	20001194
K780-130	130	135	50	Çelik - Teflon - Burç	20001195
K780-130/1	130	135	60	Çelik - Teflon - Burç	20001196

	d (f7)	D (H7)	L (+0.2/-0)	MATERIAL	Kastaş CODE
K780-130/2	130	135	40	Çelik - Teflon - Burç	20001197
K780-130/3	130	135	100	Çelik - Teflon - Burç	20001198
K780-135	135	140	100	Çelik - Teflon - Burç	20001199
K780-140	140	145	40	Çelik - Teflon - Burç	20001200
K780-140/1	140	145	60	Çelik - Teflon - Burç	20001201
K780-140/2	140	145	50	Çelik - Teflon - Burç	20001202
K780-140/3	140	145	55	Çelik - Teflon - Burç	20001203
K780-145	145	150	60	Çelik - Teflon - Burç	20001204
K780-150	150	155	40	Çelik - Teflon - Burç	20001205
K780-150/1	150	155	50	Çelik - Teflon - Burç	20001206
K780-150/2	150	155	60	Çelik - Teflon - Burç	20001207
K780-160	160	165	40	Çelik - Teflon - Burç	20001208
K780-160/1	160	165	80	Çelik - Teflon - Burç	20001209
K780-160/2	160	165	50	Çelik - Teflon - Burç	20001210
K780-160/3	160	165	60	Çelik - Teflon - Burç	20001211
K780-180	180	185	60	Çelik - Teflon - Burç	20001212
K780-210	210	215	60	Çelik - Teflon - Burç	20001213
K780-210/1	210	215	80	Çelik - Teflon - Burç	20001214

K77 - ROD GUIDE RING



K77 is a «T» formed POM guide ring widely preferred in telescopic cylinders. The dimensions and the quantities may change up to the cylinder strokes. Recommended to use with K33, K38 type rod urings.

Advantages

- Flexible guide ring configuration
- Suitable for insufficient lubrication
- Easy installation
- Low coefficient of friction
- High dimensional stability

Area of Application

- Telescopic cylinders
- Mobile machinery
- Standard industrial cylinders
- Cranes

Material	Code	Pressure (max) bar	Temperature (max) °C	Sliding Speed (max)- m/s
POM	PM9901		-40/+100	1.0

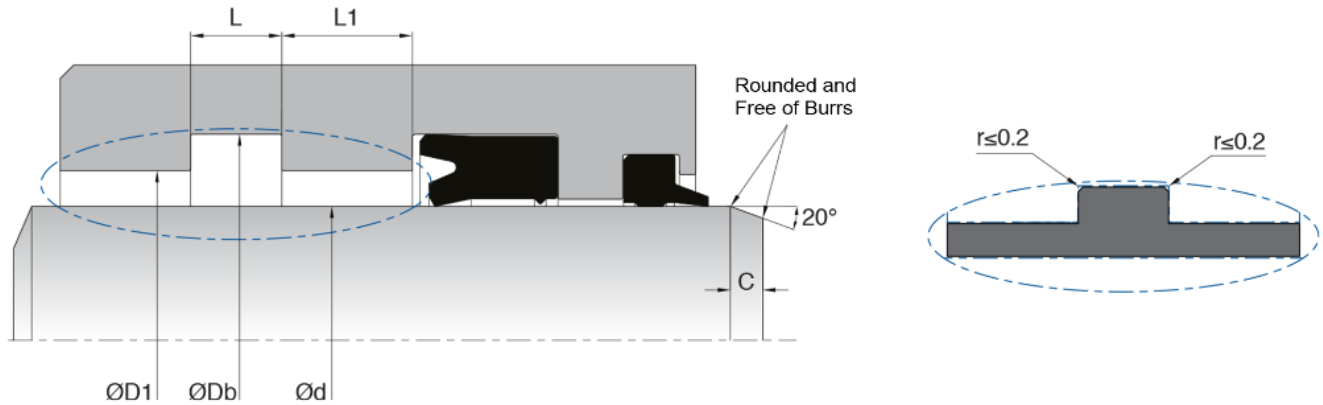

Алматы (7273)495-231
Ангарск (3955)60-70-56
Архангельск (8182)63-90-72
Астрахань (8512)99-46-04
Барнаул (3852)73-04-60
Белгород (4722)40-23-64
Благовещенск (4162)22-76-07
Брянск (4832)59-03-52
Владивосток (423)249-28-31
Владикавказ (8672)28-90-48
Владимир (4922)49-43-18
Волгоград (844)278-03-48
Вологда (8172)26-41-59
Воронеж (473)204-51-73
Екатеринбург (343)384-55-89

Россия +7(495)268-04-70

Иваново (4932)77-34-06
Ижевск (3412)26-03-58
Иркутск (395)279-98-46
Казань (843)206-01-48
Калининград (4012)72-03-81
Калуга (4842)92-23-67
Кемерово (3842)65-04-62
Киров (8332)68-02-04
Коломна (4966)23-41-49
Кострома (4942)77-07-48
Краснодар (861)203-40-90
Красноярск (391)204-63-61
Курск (4712)77-13-04
Курган (3522)50-90-47
Липецк (4742)52-20-81

Магнитогорск (3519)55-03-13
Москва (495)268-04-70
Мурманск (8152)59-64-93
Набережные Челны (8552)20-53-41
Нижний Новгород (831)429-08-12
Новокузнецк (3843)20-46-81
Ноябрьск (3496)41-32-12
Новосибирск (383)227-86-73
Омск (3812)21-46-40
Орел (4862)44-53-42
Оренбург (3532)37-68-04
Пенза (8412)22-31-16
Петрозаводск (8142)55-98-37
Псков (8112)59-10-37
Пермь (342)205-81-47

Казахстан +7(7172)727-132

Ростов-на-Дону (863)308-18-15
Рязань (4912)46-61-64
Самара (846)206-03-16
Санкт-Петербург (812)309-46-40
Саратов (845)249-38-78
Севастополь (8692)22-31-93
Саранск (8342)22-96-24
Симферополь (3652)67-13-56
Смоленск (4812)29-41-54
Сочи (862)225-72-31
Ставрополь (8652)20-65-13
Сургут (3462)77-98-35
Сыктывкар (8212)25-95-17
Тамбов (4752)50-40-97
Тверь (4822)63-31-35

Киргизия +996(312)96-26-47

Тольятти (8482)63-91-07
Томск (3822)98-41-53
Тула (4872)33-79-87
Тюмень (3452)66-21-18
Ульяновск (8422)24-23-59
Улан-Удэ (3012)59-97-51
Уфа (347)229-48-12
Хабаровск (4212)92-98-04
Чебоксары (8352)28-53-07
Челябинск (351)202-03-61
Череповец (8202)49-02-64
Чита (3022)38-34-83
Якутск (4112)23-90-97
Ярославль (4852)69-52-93

<https://kastas.nt-rt.ru/> || ksi@nt-rt.ru