

Алматы (7273)495-231
 Ангарск (3955)60-70-56
 Архангельск (8182)63-90-72
 Астрахань (8512)99-46-04
 Барнаул (3852)73-04-60
 Белгород (4722)40-23-64
 Благовещенск (4162)22-76-07
 Брянск (4832)59-03-52
 Владивосток (423)249-28-31
 Владикавказ (8672)28-90-48
 Владимир (4922)49-43-18
 Волгоград (844)278-03-48
 Вологда (8172)26-41-59
 Воронеж (473)204-51-73
 Екатеринбург (343)384-55-89

Россия +7(495)268-04-70

Иваново (4932)77-34-06
 Ижевск (3412)26-03-58
 Иркутск (395)279-98-46
 Казань (843)206-01-48
 Калининград (4012)72-03-81
 Калуга (4842)92-23-67
 Кемерово (3842)65-04-62
 Киров (8332)68-02-04
 Коломна (4966)23-41-49
 Кострома (4942)77-07-48
 Краснодар (861)203-40-90
 Красноярск (391)204-63-61
 Курск (4712)77-13-04
 Курган (3522)50-90-47
 Липецк (4742)52-20-81

Магнитогорск (3519)55-03-13
 Москва (495)268-04-70
 Мурманск (8152)59-64-93
 Набережные Челны (8552)20-53-41
 Нижний Новгород (831)429-08-12
 Новокузнецк (3843)20-46-81
 Ноябрьск (3496)41-32-12
 Новосибирск (383)227-86-73
 Омск (3812)21-46-40
 Орел (4862)44-53-42
 Оренбург (3532)37-68-04
 Пенза (8412)22-31-16
 Петрозаводск (8142)55-98-37
 Псков (8112)59-10-37
 Пермь (342)205-81-47

Казахстан +7(7172)727-132

Ростов-на-Дону (863)308-18-15
 Рязань (4912)46-61-64
 Самара (846)206-03-16
 Санкт-Петербург (812)309-46-40
 Саратов (845)249-38-78
 Севастополь (8692)22-31-93
 Саранск (8342)22-96-24
 Симферополь (3652)67-13-56
 Смоленск (4812)29-41-54
 Сочи (862)225-72-31
 Ставрополь (8652)20-65-13
 Сургут (3462)77-98-35
 Сыктывкар (8212)25-95-17
 Тамбов (4752)50-40-97
 Тверь (4822)63-31-35

Киргизия +996(312)96-26-47

Тольятти (8482)63-91-07
 Томск (3822)98-41-53
 Тула (4872)33-79-87
 Тюмень (3452)66-21-18
 Ульяновск (8422)24-23-59
 Улан-Удэ (3012)59-97-51
 Уфа (347)229-48-12
 Хабаровск (4212)92-98-04
 Чебоксары (8352)28-53-07
 Челябинск (351)202-03-61
 Череповец (8202)49-02-64
 Чита (3022)38-34-83
 Якутск (4112)23-90-97
 Ярославль (4852)69-52-93

<https://kastas.nt-rt.ru/> || ksi@nt-rt.ru

K11 – WIPER



K11 dust seals are products designed for challenging applications where the scrapping is expected from the wiper. K11 wipers are produced from TPE material which provides superior tear and rupture resistance compared to TPU wipers.

Advantages

- Suitable scraper design for icy, muddy, sticky and dusty environments
- High resistance to tearing and cutting
- Can be installed into closed grooves
- Preventing entering of contaminations through the static surface due to the special structure on the outer diameter

Area of Application

- Mining industry
- Presses
- Agriculture equipment
- Mobile machinery

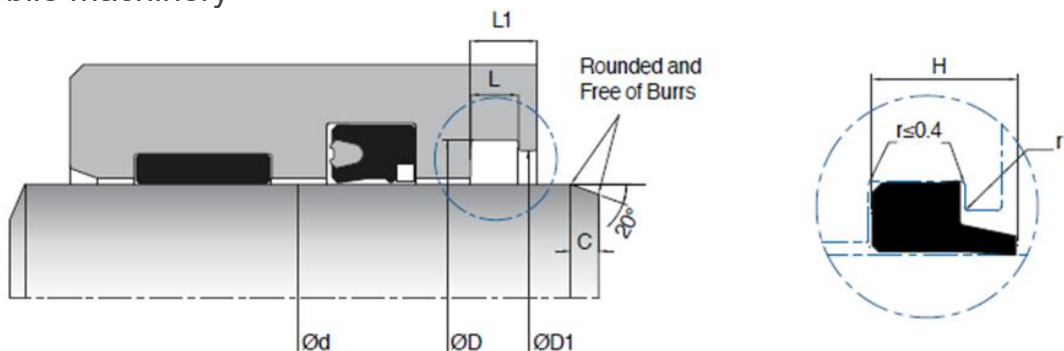

	d (f8)	D (H10)	D1 (H11)	L (+0.2/-0)	L1	H	r1	MATERIAL	Kastas CODE
K11-020	20	28	25.5	5	8	8	0.2	TP5501	10002125
K11-022	22	30	27.5	5	8	8	0.2	TP5501	10002126
K11-025	25	33	30.5	5	8	8	0.2	TP5501	10002127

	d (f8)	D (H10)	D1 (H11)	L (+0.2/-0)	L1	H	r1	MATERIAL	Kastaş CODE
K11-028	28	36	33.5	5	8	8	0.2	TP5501	10002129
K11-030	30	38	35.5	5	8	8	0.2	TP5501	10002130
K11-032	32	40	37.5	5	8	8	0.2	TP5501	10002131
K11-035	35	43	40.5	5	8	8	0.2	TP5501	10002132
K11-036	36	44	41.5	5	8	8	0.2	TP5501	10002133
K11-038	38.1	47.54	44.45	4.76	7.15	7.15	0.2	TP5501	10002134
K11-040	40	48	45.5	5	8	8	0.2	TP5501	10002136
K11-040/1	40	50.6	43.6	5.3	7	7	0.2	TP5501	10002137
K11-044	44.45	53.97	50.67	4.76	7.15	7.15	0.2	TP5501	10002138
K11-045	45	55.6	48.8	5.3	7	7	0.2	TP5501	10002139
K11-045/1	45	53	50.5	5	8	8	0.2	TP5501	10002140
K11-048	48	60	55	5	10	10	0.2	TP5501	10002141
K11-050	50	60.6	53.9	5	7	7	0.2	TP5501	10002142
K11-050/1	50	58.6	53	5.3	7	7	0.2	TP5501	10002143
K11-050/2	50	58	55.5	5	8	8	0.2	TP5501	10002144
K11-055	55	65.6	58.8	5.3	7	7	0.4	TP5501	10002145
K11-056	56	66	62	6	9	9	0.4	TP5501	10002146
K11-060	60	70	66	6	9	9	0.4	TP5501	10002148
K11-060/1	60	70.6	65.2	5.3	9	9	0.4	TP5501	10002149
K11-060/3	60	70	66	5.3	7	7	0.4	TP5501	10002151
K11-060/4	60	70	67	6.3	10	10	0.4	TP5501	10002152
K11-063	63	73.6	66.8	5	7	7	0.4	TP5501	10002153
K11-063/1	63.5	76.12	70.2	6.35	9.52	9.52	0.4	TP5501	10002154
K11-063/2	63	73	70	6.3	10	10	0.4	TP5501	10002155
K11-065	65	75	72	6.3	10	10	0.4	TP5501	10002156
K11-065/1	65	75.6	68	5.3	7	7	0.4	TP5501	10002157
K11-070	70	80	76	6	9	9	0.4	TP5501	10002158
K11-070/1	70	80.6	73.6	5.3	7	7	0.4	TP5501	10002159
K11-	70	82.2	76	7.2	12	12	0.4	TP5501	10002160

	d (f8)	D (H10)	D1 (H11)	L (+0.2/- 0)	L1	H	r1	MATERIAL	Kastaş CODE
070/3									
K11-075	75	87.2	81	7.2	12	12	0.4	TP5501	10002161
K11-080	80	90	86	6	9	9	0.4	TP5501	10002162
K11-080/1	80	92.2	86	7.2	12	12	0.4	TP5501	10002163
K11-080/2	80	90	86	6.3	10	10	0.4	TP5501	10002164
K11-085	85	98	92	7.5	11.5	11.5	0.4	TP5501	10002165
K11-090	90	100	96	6	9	9	0.6	TP5501	10002166
K11-090/1	90	102.2	96	7.2	12	12	0.6	TP5501	10002167
K11-090/2	90	100	96	6.3	10	10	0.6	TP5501	10002168
K11-095	95	107.2	101	7.2	12	12	0.6	TP5501	10002169
K11-100	100	112.2	106	7.2	12	12	0.6	TP5501	10002170
K11-100/1	100	115	110	9.5	14	14	0.6	TP5501	10002171
K11-105	105	120	112	7.2	12	12	0.6	TP5501	10002172
K11-110	110	125	120	9.5	14	14	0.6	TP5501	10002174
K11-110/1	110	122.2	116	7.2	12	12	0.6	TP5501	10002175
K11-114	114.3	133.35	123.45	9.52	14.27	14.27	0.6	TP5501	10002176
K11-115	115	127.2	121	7.2	12	12	0.6	TP5501	10002177
K11-120	120	132.2	126	7.2	12	12	0.6	TP5501	10002178
K11-125	125	140	135	9.5	14	14	0.6	TP5501	10002180
K11-125/1	125	140	135	10.2	16	16	0.6	TP5501	10002181
K11-130	130	142.2	136	7.2	12	12	0.6	TP5501	10002182
K11-135	135	150	144.3	9.5	14	14	0.6	TP5501	10002184
K11-140	140	155	150	9.5	14	14	0.6	TP5501	10002185
K11-140/1	140	155	147.5	10.2	16	16	0.6	TP5501	10002186
K11-145	145	153.6	148	5.2	7	7	0.6	TP5501	10002188
K11-150	150	165	158.6	10.2	12	12	0.6	TP5501	10002189
K11-150/1	150	166	161	8	12	12	0.6	TP5501	10002190
K11-150/2	150	165	158.6	7.2	12	12	0.6	TP5501	10002191
K11-150/3	150	162.2	156	7.7	12	12	0.6	TP5501	10002192

	d (f8)	D (H10)	D1 (H11)	L (+0.2/-0)	L1	H	r1	MATERIAL	Kastaş CODE
K11-160	160	175	167	10.2	16	16	0.6	TP5501	10002194
K11-160/1	160	172	166	7.7	12	12	0.6	TP5501	10002195
K11-160/2	160	175	170	9.5	14	14	0.6	TP5501	10002196
K11-170	170	182.2	176	7.7	12	12	0.6	TP5501	10002197
K11-170/1	170	185	178	9.5	14	14	0.6	TP5501	10002198
K11-180	180	200	190	10.2	18	18	0.6	TP5501	10002199
K11-180/2	180	195	190	9.5	14	14	0.6	TP5501	10002201
K11-185	185	205	195	10.2	18	18	0.6	TP5501	10002202
K11-185/2	185	200	192.6	10.2	16	16	0.6	TP5501	10002204
K11-190	190	205	200	9.5	14	14	0.6	TP5501	10002205
K11-190/1	190	210	200	10.2	18	18	0.6	TP5501	10002206
K11-195	195	210	202.5	9.8	16	16	0.6	TP5501	10002207
K11-200	200	220	210	10.2	18	18	0.8	TP5501	10002208
K11-200/1	200	208.6	203	5.3	7	7	0.8	TP5501	10002209
K11-200/2	200	215	206	9.5	14	14	0.8	TP5501	10002210
K11-210	210	230	220	10.2	18	18	0.8	TP5501	10002211
K11-210/1	210	225	216	9.5	14	14	0.8	TP5501	10002212
K11-215	215	237	225.4	10	18	18	0.8	TP5501	10002214
K11-220	220	240	230	12.5	18	18	0.8	TP5501	10002215
K11-220/1	220	235	227.6	10.2	16	16	0.8	TP5501	10002216
K11-230	230	250	240	10.2	18	18	0.8	TP5501	10002218
K11-230/1	230	245	237	9.5	14	14	0.8	TP5501	10002219
K11-235	235	255	245	10.2	18	18	0.8	TP5501	10002220
K11-240	240	260	250	10.2	18	18	0.8	TP5501	10002221
K11-240/1	240	255	246	9.5	14	14	0.8	TP5501	10002222
K11-245	245	265	258.5	12.5	18	18	0.8	TP5501	10002223
K11-250	250	270	263.5	12.5	18	18	0.8	TP5501	10002224
K11-260	260	280	270.5	9.8	18	18	0.8	TP5501	10002225

	d (f8)	D (H10)	D1 (H11)	L (+0.2/-0)	L1	H	r1	MATERIAL	Kastaş CODE
K11-270	270	286	280.7	7.5	12	12	0.8	TP5501	10002228
K11-280	280	300	290	10.2	15	15	0.8	TP5501	10002229
K11-280/1	280	295	288	9.5	14	14	0.8	TP5501	10002230
K11-285	285	305	298.5	12.5	18	18	0.8	TP5501	10002231
K11-290	290	310	300	10.2	18	18	0.8	TP5501	10002232
K11-295	295	315	305	12.5	18	18	0.8	TP5501	10002234
K11-300	300	316	308	7.5	12	12	0.8	TP5501	10002235
K11-320	320	340	330	10.2	18	18	0.8	TP5501	10002236
K11-340	340	360	350	10.2	18	18	0.8	TP5501	10002237
K11-345	345	365	355	10.2	18	18	0.8	TP5501	10002238
K11-400	400	420	410	10.2	18	18	0.8	TP5501	10002239
K11-450	450	470	460	10.2	18	18	0.8	TP5501	10002259

Алматы (7273)495-231
Ангарск (3955)60-70-56
Архангельск (8182)63-90-72
Астрахань (8512)99-46-04
Барнаул (3852)73-04-60
Белгород (4722)40-23-64
Благовещенск (4162)22-76-07
Брянск (4832)59-03-52
Владивосток (423)249-28-31
Владикавказ (8672)28-90-48
Владимир (4922)49-43-18
Волгоград (844)278-03-48
Вологда (8172)26-41-59
Воронеж (473)204-51-73
Екатеринбург (343)384-55-89

Иваново (4932)77-34-06
Ижевск (3412)26-03-58
Иркутск (395)279-98-46
Казань (843)206-01-48
Калининград (4012)72-03-81
Калуга (4842)92-23-67
Кемерово (3842)65-04-62
Киров (8332)68-02-04
Коломна (4966)23-41-49
Кострома (4942)77-07-48
Краснодар (861)203-40-90
Красноярск (391)204-63-61
Курск (4712)77-13-04
Курган (3522)50-90-47
Липецк (4742)52-20-81

Магнитогорск (3519)55-03-13
Москва (495)268-04-70
Мурманск (8152)59-64-93
Набережные Челны (8552)20-53-41
Нижний Новгород (831)429-08-12
Новокузнецк (3843)20-46-81
Ноябрьск (3496)41-32-12
Новосибирск (383)227-86-73
Омск (3812)21-46-40
Орел (4862)44-53-42
Оренбург (3532)37-68-04
Пенза (8412)22-31-16
Петрозаводск (8142)55-98-37
Псков (8112)59-10-37
Пермь (342)205-81-47

Ростов-на-Дону (863)308-18-15
Рязань (4912)46-61-64
Самара (846)206-03-16
Санкт-Петербург (812)309-46-40
Саратов (845)249-38-78
Севастополь (8692)22-31-93
Саранск (8342)22-96-24
Симферополь (3652)67-13-56
Смоленск (4812)29-41-54
Сочи (862)225-72-31
Ставрополь (8652)20-65-13
Сургут (3462)77-98-35
Сыктывкар (8212)25-95-17
Тамбов (4752)50-40-97
Тверь (4822)63-31-35

Тольятти (8482)63-91-07
Томск (3822)98-41-53
Тула (4872)33-79-87
Тюмень (3452)66-21-18
Ульяновск (8422)24-23-59
Улан-Удэ (3012)59-97-51
Уфа (347)229-48-12
Хабаровск (4212)92-98-04
Чебоксары (8352)28-53-07
Челябинск (351)202-03-61
Череповец (8202)49-02-64
Чита (3022)38-34-83
Якутск (4112)23-90-97
Ярославль (4852)69-52-93

Россия +7(495)268-04-70

Казахстан +7(7172)727-132

Киргизия +996(312)96-26-47

<https://kastas.nt-rt.ru/> || ksi@nt-rt.ru