

Алматы (7273)495-231
 Ангарск (3955)60-70-56
 Архангельск (8182)63-90-72
 Астрахань (8512)99-46-04
 Барнаул (3852)73-04-60
 Белгород (4722)40-23-64
 Благовещенск (4162)22-76-07
 Брянск (4832)59-03-52
 Владивосток (423)249-28-31
 Владикавказ (8672)28-90-48
 Владимир (4922)49-43-18
 Волгоград (844)278-03-48
 Вологда (8172)26-41-59
 Воронеж (473)204-51-73
 Екатеринбург (343)384-55-89

Иваново (4932)77-34-06
 Ижевск (3412)26-03-58
 Иркутск (395)279-98-46
 Казань (843)206-01-48
 Калининград (4012)72-03-81
 Калуга (4842)92-23-67
 Кемерово (3842)65-04-62
 Киров (8332)68-02-04
 Коломна (4966)23-41-49
 Кострома (4942)77-07-48
 Краснодар (861)203-40-90
 Красноярск (391)204-63-61
 Курск (4712)77-13-04
 Курган (3522)50-90-47
 Липецк (4742)52-20-81

Магнитогорск (3519)55-03-13
 Москва (495)268-04-70
 Ижевск (3412)26-03-58
 Мурманск (8152)59-64-93
 Набережные Челны (8552)20-53-41
 Нижний Новгород (831)429-08-12
 Новокузнецк (3843)20-46-81
 Ноябрьск (3496)41-32-12
 Новосибирск (383)227-86-73
 Омск (3812)21-46-40
 Орел (4862)44-53-42
 Оренбург (3532)37-68-04
 Пенза (8412)22-31-16
 Петрозаводск (8142)55-98-37
 Псков (8112)59-10-37
 Пермь (342)205-81-47

Ростов-на-Дону (863)308-18-15
 Рязань (4912)46-61-64
 Самара (846)206-03-16
 Санкт-Петербург (812)309-46-40
 Саратов (845)249-38-78
 Севастополь (8692)22-31-93
 Саранск (8342)22-96-24
 Симферополь (3652)67-13-56
 Смоленск (4812)29-41-54
 Сочи (862)225-72-31
 Ставрополь (8652)20-65-13
 Сургут (3462)77-98-35
 Сыктывкар (8212)25-95-17
 Тамбов (4752)50-40-97
 Тверь (4822)63-31-35

Тольятти (8482)63-91-07
 Томск (3822)98-41-53
 Тула (4872)33-79-87
 Тюмень (3452)66-21-18
 Ульяновск (8422)24-23-59
 Улан-Удэ (3012)59-97-51
 Уфа (347)229-48-12
 Хабаровск (4212)92-98-04
 Чебоксары (8352)28-53-07
 Челябинск (351)202-03-61
 Череповец (8202)49-02-64
 Чита (3022)38-34-83
 Якутск (4112)23-90-97
 Ярославль (4852)69-52-93

Россия +7(495)268-04-70

Казахстан +7(7172)727-132

Киргизия +996(312)96-26-47

<https://kastas.nt-rt.ru/> || ksi@nt-rt.ru

K160 - PNEUMATIC PISTON SEAL

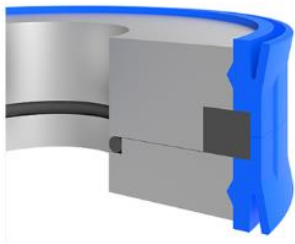

K160 pneumatic piston seal is a polyurethane sealing element that can be used back to back with a magnet and has a specially designed nutring structure. Note: It can be produced up to Ø25 mm bore diameter. * Misc. parts in the visual such as magnet and aluminum are not included to K160. The SKU consists of the TPU sealing ring

Advantages

- Position control due to magnet
- Suitable for short stroke cylinders
- Cushioning feature
- Low friction

Area of Application

- Recommended for use in cylinders according ISO and CETOP.

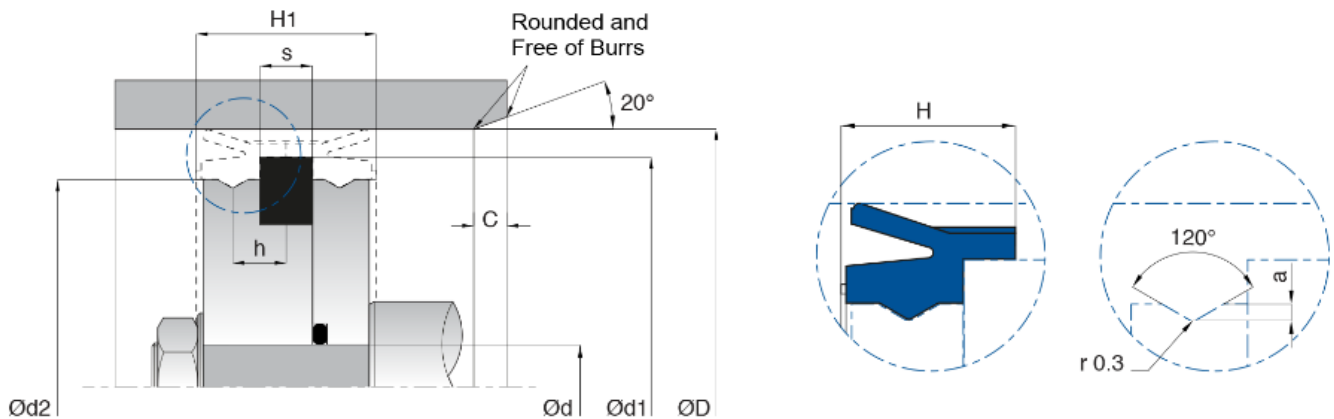

Material	Code	Pressure (max) bar	Temperature (max) °C	Sliding Speed (max)- m/s
PU	PU9204	16	-30/+100	1.0

K66 - PNEUMATIC PISTON SEAL



K66 pneumatic piston seal is a U-ring type double-acting sealing element that can be easily installed to the housing on the piston head due to its special design.

Advantages

- Low coefficient of friction
- Good abrasion resistance
- Easy installation
- High temperature resistance
- Double acting

Area of Application

- Recommended for use in cylinders according ISO and CETOP.

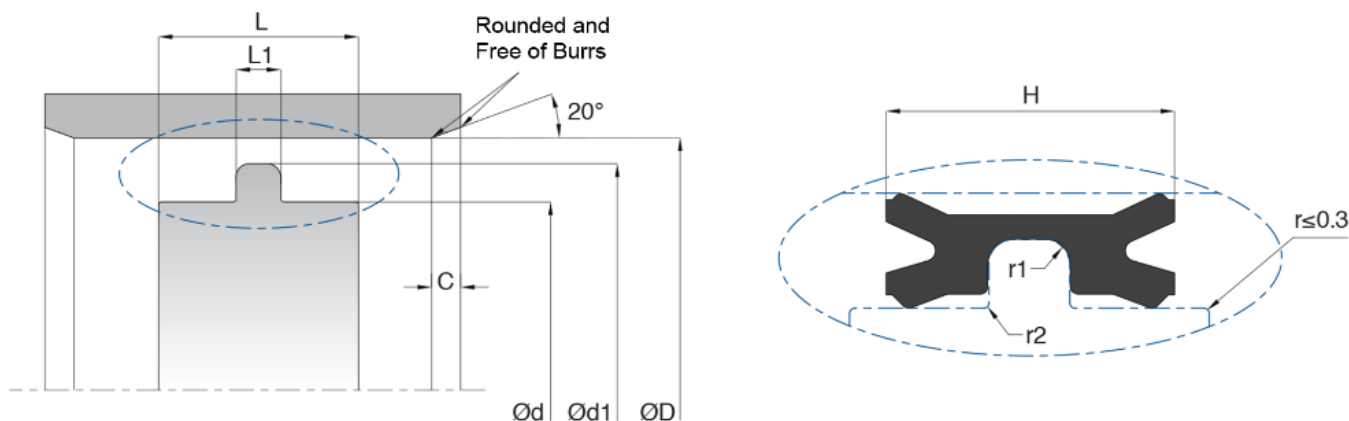

Material	Code	Pressure (max) bar	Temperature (max) °C	Sliding Speed (max)- m/s
NBR	NB8001	12	-30/+105	1.0

K506 - PNEUMATIC PISTON SEAL



K506 pneumatic piston seal is the single acting sealing element that can provide good sealing at variable pressures with its U-ring structure.

Advantages

- Superior sealing performance
- Low coefficient of friction
- Good Abrasion Resistance
- Easy installation
- High temperature resistance
- Can be used in both hydraulic and pneumatic cylinders

Area of Application

- Recommended for use in cylinders according ISO and CETOP.

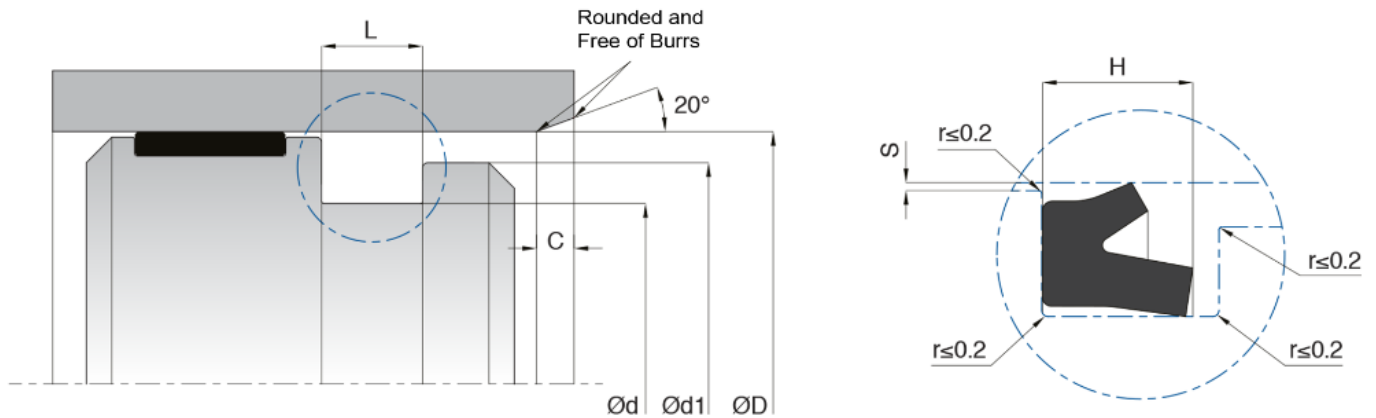

Material	Code	Pressure (max) bar	Temperature (max) °C	Sliding Speed (max)- m/s
NBR	NB8501	12	-30/+105	1.0

K761 - PNEUMATIC PISTON SEAL



K761 pneumatic piston seal is a double-acting pneumatic sealing element consists of carbon filled PTFE and NBR o-ring, which can operate at high speeds and dry.

Advantages

- Superior sealing performance
- High abrasion resistance
- Low coefficient of friction
- High temperature resistance
- High speeds

Area of Application

- Recommended for use in cylinders according ISO and CETOP.

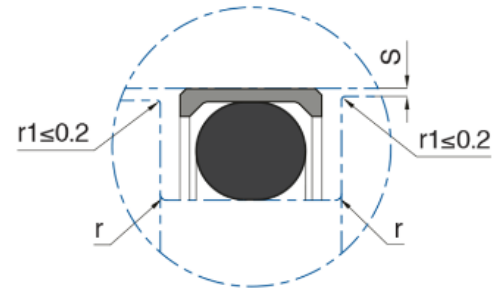
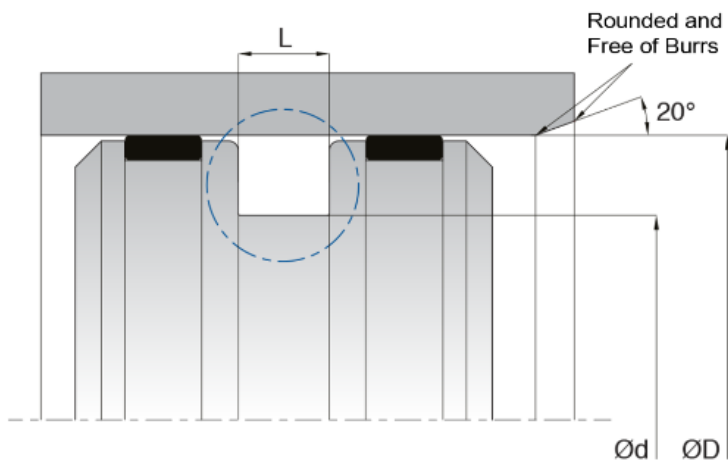

Material	Code	Pressure (max) bar	Temperature (max) °C	Sliding Speed (max)- m/s
PTFE	PT6005	16	-30/+105	4.0
NBR	NB7001			

K161 - PNEUMATIC PISTON SEAL

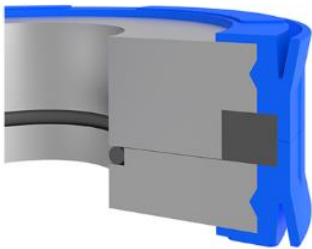

K161 pneumatic piston seal is a polyurethane sealing element that can be used back to back with a magnet and has special nutring design and impact-absorbing structure at the end of the stroke. Note: It can be produced up to Ø25 mm bore diameter. * Misc. parts in the visual such as magnet and aluminum are not included to K160. The SKU consists of the TPU sealing ring

Advantages

- Position control due to magnet
- Suitable for short stroke cylinders
- Cushioning feature
- Low friction

Area of Application

- Recommended for use in cylinders according ISO and CETOP.

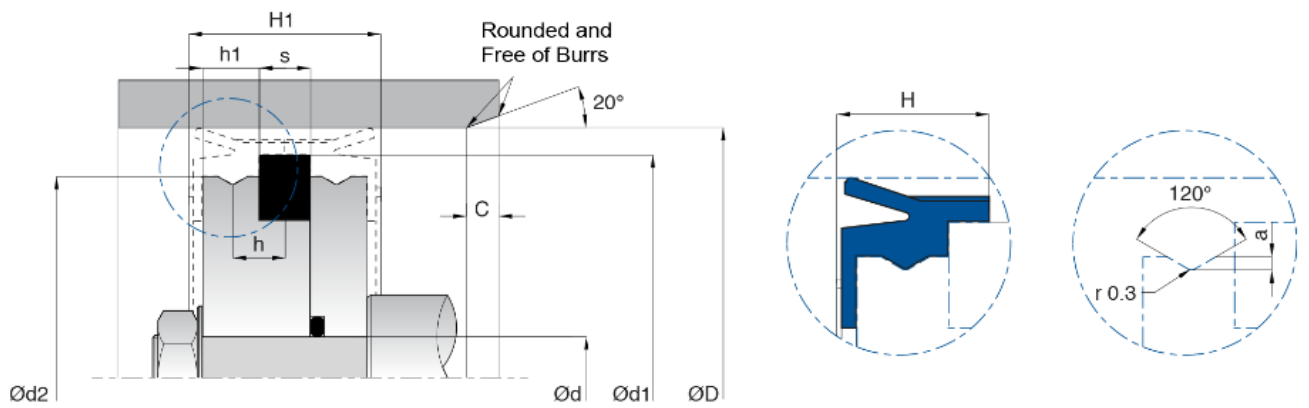

Material	Code	Pressure (max) bar	Temperature (max) °C	Sliding Speed (max)- m/s
PU	PU9204	16	-30/+100	1.0

Алматы (7273)495-231
Ангарск (3955)60-70-56
Архангельск (8182)63-90-72
Астрахань (8512)99-46-04
Барнаул (3852)73-04-60
Белгород (4722)40-23-64
Благовещенск (4162)22-76-07
Брянск (4832)59-03-52
Владивосток (423)249-28-31
Владикавказ (8672)28-90-48
Владимир (4922)49-43-18
Волгоград (844)278-03-48
Вологда (8172)26-41-59
Воронеж (473)204-51-73
Екатеринбург (343)384-55-89

Россия +7(495)268-04-70

Иваново (4932)77-34-06
Ижевск (3412)26-03-58
Иркутск (395)279-98-46
Казань (843)206-01-48
Калининград (4012)72-03-81
Калуга (4842)92-23-67
Кемерово (3842)65-04-62
Киров (8332)68-02-04
Коломна (4966)23-41-49
Кострома (4942)77-07-48
Краснодар (861)203-40-90
Красноярск (391)204-63-61
Курск (4712)77-13-04
Курган (3522)50-90-47
Липецк (4742)52-20-81

Магнитогорск (3519)55-03-13
Москва (495)268-04-70
Мурманск (8152)59-64-93
Набережные Челны (8552)20-53-41
Нижний Новгород (831)429-08-12
Новокузнецк (3843)20-46-81
Ноябрьск (3496)41-32-12
Новосибирск (383)227-86-73
Омск (3812)21-46-40
Орел (4862)44-53-42
Оренбург (3532)37-68-04
Пенза (8412)22-31-16
Петрозаводск (8142)55-98-37
Псков (8112)59-10-37
Пермь (342)205-81-47

Казахстан +7(7172)727-132

Ростов-на-Дону (863)308-18-15
Рязань (4912)46-61-64
Самара (846)206-03-16
Санкт-Петербург (812)309-46-40
Саратов (845)249-38-78
Севастополь (8692)22-31-93
Саранск (8342)22-96-24
Симферополь (3652)67-13-56
Смоленск (4812)29-41-54
Сочи (862)225-72-31
Ставрополь (8652)20-65-13
Сургут (3462)77-98-35
Сыктывкар (8212)25-95-17
Тамбов (4752)50-40-97
Тверь (4822)63-31-35

Киргизия +996(312)96-26-47

Тольятти (8482)63-91-07
Томск (3822)98-41-53
Тула (4872)33-79-87
Тюмень (3452)66-21-18
Ульяновск (8422)24-23-59
Улан-Удэ (3012)59-97-51
Уфа (347)229-48-12
Хабаровск (4212)92-98-04
Чебоксары (8352)28-53-07
Челябинск (351)202-03-61
Череповец (8202)49-02-64
Чита (3022)38-34-83
Якутск (4112)23-90-97
Ярославль (4852)69-52-93

<https://kastas.nt-rt.ru/> || ksi@nt-rt.ru