

Алматы (7273)495-231  
 Ангарск (3955)60-70-56  
 Архангельск (8182)63-90-72  
 Астрахань (8512)99-46-04  
 Барнаул (3852)73-04-60  
 Белгород (4722)40-23-64  
 Благовещенск (4162)22-76-07  
 Брянск (4832)59-03-52  
 Владивосток (423)249-28-31  
 Владикавказ (8672)28-90-48  
 Владимир (4922)49-43-18  
 Волгоград (844)278-03-48  
 Вологда (8172)26-41-59  
 Воронеж (473)204-51-73  
 Екатеринбург (343)384-55-89

Иваново (4932)77-34-06  
 Ижевск (3412)26-03-58  
 Иркутск (395)279-98-46  
 Казань (843)206-01-48  
 Калининград (4012)72-03-81  
 Калуга (4842)92-23-67  
 Кемерово (3842)65-04-62  
 Киров (8332)68-02-04  
 Коломна (4966)23-41-49  
 Кострома (4942)77-07-48  
 Краснодар (861)203-40-90  
 Красноярск (391)204-63-61  
 Курск (4712)77-13-04  
 Курган (352)50-90-47  
 Липецк (4742)52-20-81

Магнитогорск (3519)55-03-13  
 Москва (495)268-04-70  
 Ижевск (3412)26-03-58  
 Мурманск (8152)59-64-93  
 Набережные Челны (8552)20-53-41  
 Нижний Новгород (831)429-08-12  
 Новокузнецк (3843)20-46-81  
 Ноябрьск (3496)41-32-12  
 Новосибирск (383)227-86-73  
 Омск (3812)21-46-40  
 Орел (4862)44-53-42  
 Оренбург (3532)37-68-04  
 Пенза (8412)22-31-16  
 Петрозаводск (8142)55-98-37  
 Псков (8112)59-10-37  
 Пермь (342)205-81-47

Ростов-на-Дону (863)308-18-15  
 Рязань (4912)46-61-64  
 Самара (846)206-03-16  
 Санкт-Петербург (812)309-46-40  
 Саратов (845)249-38-78  
 Севастополь (8692)22-31-93  
 Саранск (8342)22-96-24  
 Симферополь (3652)67-13-56  
 Смоленск (4812)29-41-54  
 Сочи (862)225-72-31  
 Ставрополь (8652)20-65-13  
 Сургут (3462)77-98-35  
 Сыктывкар (8212)25-95-17  
 Тамбов (4752)50-40-97  
 Тверь (4822)63-31-35

Тольятти (8482)63-91-07  
 Томск (3822)98-41-53  
 Тула (4872)33-79-87  
 Тюмень (3452)66-21-18  
 Ульяновск (8422)24-23-59  
 Улан-Удэ (3012)59-97-51  
 Уфа (347)229-48-12  
 Хабаровск (4212)92-98-04  
 Чебоксары (8352)28-53-07  
 Челябинск (351)202-03-61  
 Череповец (8202)49-02-64  
 Чита (3022)38-34-83  
 Якутск (4112)23-90-97  
 Ярославль (4852)69-52-93

Россия +7(495)268-04-70

Казахстан +7(7172)727-132

Киргизия +996(312)96-26-47

<https://kastas.nt-rt.ru/> || [ksi@nt-rt.ru](mailto:ksi@nt-rt.ru)

## K17X - HIGH PERFORMANCE PISTON SEAL



K17X is an innovative piston seal, consists of PTFE sealing ring and energizer elastomer ring. The special design of the PTFE ring increases the extrusion resistance performance while the blow-by risk is minimized. K17X provides low friction and minimal break-out forces in demanding hydraulic applications.

### Advantages

- No blow-by effect
- Low friction and stick-slip free
- Excellent dynamic and static sealing
- Long service life
- High extrusion resistance
- Reduced Blow-by risk
- High speeds and frequencies
- Designed for grooves according to ISO 7425/1

### Area of Application

- Cranes
- Injection moulding machines
- Hydraulic press cylinders
- Forklifts
- Construction machinery
- Servo cylinders
- Hydraulic breakers
- Wind turbines
- Automotive industry

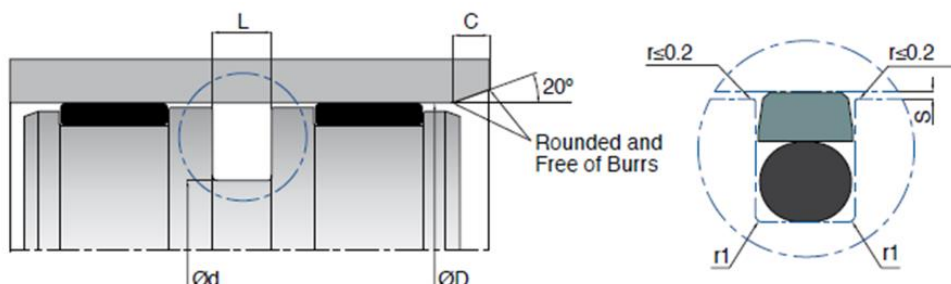

	<b>D (H8)</b>	<b>d (h9)</b>	<b>L (+0.2/- 0)</b>	<b>r1</b>	<b>C</b>	<b>O-Ring</b>	<b>MATERIAL</b>	<b>Kastaş CODE</b>
K17X 025-017.5	25	17.5	3.2	0.6	4.5	17.13x2.62	PT6003	10003040
K17X 028-020.5	28	20.5	3.2	0.6	4.5	20.29x2.62	PT6003	10003041
K17X 030-022.5	30	22.5	3.2	0.6	4.5	22.22x2.62	PT6003	10003042
K17X 032-024.5	32	24.5	3.2	0.6	4.5	23.81x2.62	PT6003	10003043
K17X 034-026.5	34	26.5	3.2	0.6	4.5	25.07x2.62	PT6003	10003044
K17X 035-027.5	35	27.5	3.2	0.6	4.5	26.64x2.62	PT6003	10003045
K17X 040-029	40	29	4.2	1	6	28.17x3.53	PT6003	10003046
K17X 045-034	45	34	4.2	1	6	32.92x3.53	PT6003	10003047
K17X 048-037	48	37	4.2	1	6	36.10x3.53	PT6003	10003048
K17X 050-039	50	39	4.2	1	6	37.69x3.53	PT6003	10003050
K17X 055-044	55	44	4.2	1	6	42.86x3.53	PT6003	10003052
K17X 060-049	60	49	4.2	1	6	47.63x3.53	PT6003	10003053
K17X 063-052	63	52	4.2	1	6	50.80x3.53	PT6003	10003054
K17X 065-054	65	54	4.2	1	6	53.57x3.53	PT6003	10003055
K17X 070-054.5	70	54.5	6.3	1.3	8	53.34x5.33	PT6003	10003056
K17X 070-059	70	59	4.2	1	6	58.74x3.53	PT6003	10003057
K17X 075-064	75	64	4.2	1	6	63.09x3.53	PT6003	10003058
K17X 080-064.5	80	64.5	6.3	1.3	8	62.87x5.33	PT6003	10003059
K17X 085-069.5	85	69.5	6.3	1.3	8	69.22x5.33	PT6003	10003060
K17X 090-074.5	90	74.5	6.3	1.3	8	72.40x5.33	PT6003	10003061
K17X 095-079.5	95	79.5	6.3	1.3	8	78.74x5.33	PT6003	10003062
K17X 100-084.5	100	84.5	6.3	1.3	8	81.92x5.33	PT6003	10003063

	<b>D (H8)</b>	<b>d (h9)</b>	<b>L (+0.2/- 0)</b>	<b>r1</b>	<b>C</b>	<b>O-Ring</b>	<b>MATERIAL</b>	<b>Kastaş CODE</b>
K17X 105-089.5	105	89.5	6.3	1.3	8	88.27x5.33	PT6003	10003065
K17X 110-094.5	110	94.5	6.3	1.3	8	91.44x5.33	PT6003	10003066
K17X 115-099.5	115	99.5	6.3	1.3	8	97.80x5.33	PT6003	10003068
K17X 120-104.5	120	104.5	6.3	1.3	8	104.14x5.33	PT6003	10003069
K17X 125-109.5	125	109.5	6.3	1.3	8	107.32x5.33	PT6003	10003071
K17X 127-111.50	127	111.5	6.3	1.3	8	109.54x5.33	PT6003	10003072
K17X 130-114.5	130	114.5	6.3	1.3	8	113.67x5.33	PT6003	10003073
K17X 140-124.5	140	124.5	6.3	1.3	8	123.80x5.33	PT6003	10003074
K17X 150-129	150	129	8.1	1.8	10.5	126.37x6.99	PT6003	10003075
K17X 155-134	155	134	8.1	1.8	10.5	132.72x6.99	PT6003	10003076
K17X 160-139	160	139	8.1	1.8	10.5	135.90x6.99	PT6003	10003077
K17X 165-144	165	144	8.1	1.8	10.5	142.24x6.99	PT6003	10003078
K17X 170-149	170	149	8.1	1.8	10.5	148.60X6.99	PT6003	10003079
K17X 175-154	175	154	8.1	1.8	10.5	151.77x6.99	PT6003	10003080
K17X 180-159	180	159	8.1	1.8	10.5	155.60x6.99	PT6003	10003081
K17X 185-164	185	164	8.1	1.8	10.5	161.90x6.99	PT6003	10003082
K17X 190-169	190	169	8.1	1.8	10.5	168.30x6.99	PT6003	10003083
K17X 195-174	195	174	8.1	1.8	10.5	170.82x6.99	PT6003	10003084
K17X 200-179	200	179	8.1	1.8	10.5	177.17x6.99	PT6003	10003085
K17X 205-184	205	184	8.1	1.8	10.5	183.52X6.99	PT6003	10003086
K17X 210-189	210	189	8.1	1.8	10.5	187.3X6.99	PT6003	10003087
K17X 215-194	215	194	8.1	1.8	10.5	189.87x6.99	PT6003	10003088

	<b>D (H8)</b>	<b>d (h9)</b>	<b>L (+0.2/- 0)</b>	<b>r1</b>	<b>C</b>	<b>O-Ring</b>	<b>MATERIAL</b>	<b>Kastaş CODE</b>
K17X 220-199	220	199	8.1	1.8	10.5	196.22x6.99	PT6003	10003089
K17X 225-204	225	204	8.1	1.8	10.5	199.80x6.99	PT6003	10003090
K17X 230-209	230	209	8.1	1.8	10.5	202.57x6.99	PT6003	10003091
K17X 240-219	240	219	8.1	1.8	10.5	215.27X6.99	PT6003	10003092
K17X 245-224	245	224	8.1	1.8	10.5	221.62X6.99	PT6003	10003093
K17X 250-229	250	229	8.1	1.8	10.5	227.97x6.99	PT6003	10003094
K17X 255-234	255	234	8.1	1.8	10.5	227.97X6.99	PT6003	10003095
K17X 260-239	260	239	8.1	1.8	10.5	234.32x6.99	PT6003	10003096
K17X 265-244	265	244	8.1	1.8	10.5	240.67x6.99	PT6003	10003097
K17X 270-249	270	249	8.1	1.8	10.5	247.00x6.99	PT6003	10003098
K17X 275-254	275	254	8.1	1.8	10.5	253.57x6.99	PT6003	10003099
K17X 280-259	280	259	8.1	1.8	10.5	253.57x6.99	PT6003	10003100
K17X 290-269	290	269	8.1	1.8	10.5	266.07x6.99	PT6003	10003101
K17X 300-279	300	279	8.1	1.8	10.5	272.40x6.99	PT6003	10003102
K17X 305-284	305	284	8.1	1.8	10.5	278.77x6.99	PT6003	10003103
K17X 310-289	310	289	8.1	1.8	10.5	285.1x6.99	PT6003	10003104
K17X 315-294	315	294	8.1	1.8	10.5	291.47x6.99	PT6003	10003105
K17X 320-299	320	299	8.1	1.8	10.5	291.47x6.99	PT6003	10003106
K17X 325-304	325	304	8.1	1.8	10.5	297.88x6.99	PT6003	10003107
K17X 330-305.5	330	305.5	8.1	1.8	12	304.17x6.99	PT6003	10003108
K17X 340-315.5	340	315.5	8.1	1.8	12	310.50x6.99	PT6003	10003109
K17X 350-325.5	350	325.5	8.1	1.8	12	323.20x6.99	PT6003	10003110

	D (H8)	d (h9)	L (+0.2/- 0)	r1	C	O-Ring	MATERIAL	Kastaş CODE
K17X 360- 335.5	360	335.5	8.1	1.8	12	329.57x6.99	PT6003	10003111
K17X 365- 340.5	365	340.5	8.1	1.8	12	335.90x6.99	PT6003	10003112
K17X 370- 345.5	370	345.5	8.1	1.8	12	342.27x6.99	PT6003	10003113
K17X 375- 350.5	375	350.5	8.1	1.8	12	342.27X6.99	PT6003	10003114
K17X 380- 355.5	380	355.5	8.1	1.8	12	354.90x6.99	PT6003	10003115
K17X 390- 365.5	390	365.5	8.1	1.8	12	354.90x6.99	PT6003	10003116
K17X 400- 375.5	400	375.5	8.1	1.8	12	367.67x6.99	PT6003	10003117
K17X 420- 395.5	420	395.5	8.1	1.8	12	393.07x6.99	PT6003	10003118

## K17 - PISTON SEAL



K17 consists of PTFE sealing ring and energizer elastomer oring. It has a wide range of usage thanks to the suitability with ISO housings. It can be produced from PTFE materials with different fillers.

### Advantages

- Low friction and stick-slip free
- Excellent dynamic and static sealing
- Long service life
- High extrusion resistance
- No hydrodynamic pressure
- High speeds and frequencies
- Designed for grooves according to ISO 7425/1

### Area of Application

- Cranes
- Injection moulding machines
- Hydraulic press cylinders
- Forklifts
- Construction machinery
- Servo cylinders
- Hydraulic breakers
- Wind turbines
- Automotive industry

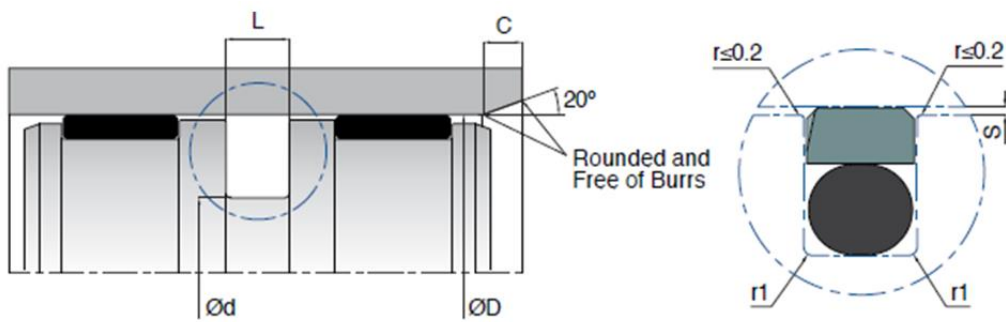

	<b>D (H8)</b>	<b>d (h9)</b>	<b>L (+0.2/- 0)</b>	<b>r1</b>	<b>C</b>	<b>O-Ring</b>	<b>MATERIAL</b>	<b>Kastaş CODE</b>
K17 008-003.1	8	3.1	2.2	0.4	3	2.90x1.78	PT6003	10002539
K17 010-005.1	10	5.1	2.2	0.4	3	4.76x1.78	PT6003	10002541
K17 012-007.1	12	7.1	2.2	0.4	3	6.75x1.78	PT6003	10002542
K17 014-009.1	14	9.1	2.2	0.4	3	8.73x1.78	PT6003	10002544
K17 015-007.5	15	7.5	3.2	0.6	4.5	7.60x2.62	PT6003	10002547
K17 016-008.5	16	8.5	3.2	0.6	4.5	7.60x2.62	PT6003	10002549
K17 018-010.5	18	10.5	3.2	0.6	4.5	9.92x2.62	PT6003	10002556
K17 018-013.1	18	13.1	2.2	0.6	3	12.42x1.78	PT6003	10002557
K17 020-012.5	20	12.5	3.2	0.6	4.5	12.37x2.62	PT6003	10002559
K17 020-015.1	20	15.1	2.2	0.6	3	14.00x1.78	PT6003	10002562
K17 022-014.5	22	14.5	3.2	0.6	4.5	13.95x2.62	PT6003	10002565
K17 022.15- 14.65	22.15	14.65	3.2	0.6	4.5	13.95x2.62	PT6003	10002564
K17 024-016.5	24	16.5	3.2	0.6	4.5	15.88x2.62	PT6003	10002570
K17 025-014	25	14	4.2	1	6	13.87x3.53	PT6003	10002573
K17 025-017.5	25	17.5	3.2	0.6	4.5	17.13x2.62	PT6003	10002575
K17 025-020.1	25	20.1	2.2	0.6	3	20.35x1.78	PT6003	10002579
K17 028-020.5	28	20.5	3.2	0.6	4.5	20.29x2.62	PT6003	10002583
K17 030-022.5	30	22.5	3.2	0.6	4.5	21.89x2.62	PT6003	10002587
K17 032-021	32	21	4.2	1	6	20.22x3.53	PT6003	10002591
K17 032-024.5	32	24.5	3.2	0.6	4.5	23.81x2.62	PT6003	10002593
K17 032-027.1	32	27.1	2.2	0.6	3	26.70x1.78	PT6003	10002596
K17 034-026.5	34	26.5	3.2	0.6	4.5	25.07x2.62	PT6003	10002598
K17 035-024	35	24	4.2	1	6	23.40x3.53	PT6003	10002599
K17 035-027.5	35	27.5	3.2	0.6	4.5	26.64x2.62	PT6003	10002600
K17 035-030.1	35	30.1	2.2	0.6	3	29.87x1.78	PT6003	10002602
K17 036-028.5	36	28.5	3.2	0.6	4.5	28.25x2.62	PT6003	10002603
K17 038-030.5	38	30.5	3.2	1	4.5	29.82x2.62	PT6003	10002605
K17 040-024.5	40	24.5	6.3	1.3	8	23.17x5.33	PT6003	10002608
K17 040-029	40	29	4.2	1	6	28.17x3.53	PT6003	10002610

	<b>D (H8)</b>	<b>d (h9)</b>	<b>L (+0.2/- 0)</b>	<b>r1</b>	<b>C</b>	<b>O-Ring</b>	<b>MATERIAL</b>	<b>Kastaş CODE</b>
K17 040-032.5	40	32.5	3.2	0.6	4.5	31.42x2.62	PT6003	10002617
K17 042-031	42	31	4.2	1	6	29.75x3.53	PT6003	10002621
K17 045-034	45	34	4.2	1	6	32.92x3.53	PT6003	10002625
K17 048-037	48	37	4.2	1	6	36.1x3.53	PT6003	10002630
K17 050- 034.5/1	50	34.5	6.3	1	8	34.29x5.33	PT6003	10002635
K17 050-039	50	39	4.2	1	6	37.69x3.53	PT6003	10002636
K17 050-042.5	50	42.5	3.2	0.6	4.5	42.52x2.62	PT6003	10002643
K17 050.8- 039.8	50.8	39.8	4.2	1	6	39.69x3.53	PT6003	10002632
K17 052-041	52	41	4.2	1	6	39.69x3.53	PT6003	10002648
K17 055-044	55	44	4.2	1	6	42.86x3.53	PT6003	10002653
K17 057-046	57	46	4.2	1	6	44.45x3.53	PT6003	10002659
K17 058-047	58	47	4.2	1	6	46.04x3.53	PT6003	10002660
K17 060-044.5	60	44.5	6.3	1	8	43.82x5.33	PT6003	10002662
K17 060-049	60	49	4.2	1	6	47.63x3.53	PT6003	10002665
K17 063-047.5	63	47.5	6.3	1.3	8	47.00x5.33	PT6003	10002673
K17 063-052	63	52	4.2	1	6	50.80x3.53	PT6003	10002676
K17 063-055.5	63	55.5	3.2	0.6	4.5	55.25x2.62	PT6003	10002678
K17 063.5-056	63.5	56	3.2	0.6	4.5	55.25x2.62	PT6003	10002671
K17 065-049.5	65	49.5	6.3	1.3	8	47.00x5.33	PT6003	10002681
K17 065-054	65	54	4.2	1	6	52.39x3.53	PT6003	10002685
K17 068-057	68	57	4.2	1	6	55.56x3.53	PT6003	10002690
K17 070-054.5	70	54.5	6.3	1.3	8	53.34x5.33	PT6003	10002691
K17 070-059	70	59	4.2	1	6	57.15x3.53	PT6003	10002694
K17 075-059.5	75	59.5	6.3	1.3	8	56.52x5.33	PT6003	10002700
K17 075-064	75	64	4.2	1	6	63.09x3.53	PT6003	10002701
K17 080-059	80	59	8.1	1.8	10.5	58.00x6.99	PT6003	10002706
K17 080-064.5	80	64.5	6.3	1.3	8	62.87x5.33	PT6003	10002708
K17 080-069	80	69	4.2	1	6	68.26x3.53	PT6003	10002711
K17 082.5-067	82.5	67	6.3	1.3	8	66.04x5.33	PT6003	10002714
K17 085-064	85	64	8.1	1.8	10.5	63.00x6.99	PT6003	10002716
K17 085-069.5	85	69.5	6.3	1.3	8	69.22x5.33	PT6003	10002718
K17 085-074	85	74	4.2	1	6	73.03x3.53	PT6003	10002720
K17 090-069	90	69	8.1	1.8	10.5	68x6.99	PT6003	10002723
K17 090-074.5	90	74.5	6.3	1.3	8	72.40x5.33	PT6003	10002725
K17 090-079	90	79	4.2	1	6	78.97x3.53	PT6003	10002729

	<b>D (H8)</b>	<b>d (h9)</b>	<b>L (+0.2/- 0)</b>	<b>r1</b>	<b>C</b>	<b>O-Ring</b>	<b>MATERIAL</b>	<b>Kastaş CODE</b>
K17 095-074	95	74	8.1	1.8	10.5	72.39x6.99	PT6003	10002731
K17 095-079.5	95	79.5	6.3	1.3	8	78.74x5.33	PT6003	10002732
K17 095-084	95	84	4.2	1	6	82.14x3.53	PT6003	10002734
K17 100-079	100	79	8.1	1.8	10.5	77.00x6.99	PT6003	10002736
K17 100-084.5	100	84.5	6.3	1.3	8	81.92x5.33	PT6003	10002738
K17 100-089	100	89	4.2	1	6	88.50x3.53	PT6003	10002740
K17 101.6- 086.1	101.6	86.1	6.3	1.3	8	85.09x5.33	PT6003	10002742
K17 105-089.5	105	89.5	6.3	1.3	8	88.27x5.33	PT6003	10002747
K17 105-094	105	94	4.2	1	6	91.67x3.53	PT6003	10002749
K17 108-092.5	108	92.5	6.3	1.3	8	91.44x5.33	PT6003	10002750
K17 110-089	110	89	8.1	1.8	10.5	88.00x6.99	PT6003	10002751
K17 110-094.5	110	94.5	6.3	1.3	8	91.44x5.33	PT6003	10002753
K17 110-099	110	99	4.2	1	6	98.02x3.53	PT6003	10002755
K17 115-094	115	94	8.1	1.8	10.5	92.00x7	PT6003	10002759
K17 115-099.5	115	99.5	6.3	1.3	8	97.80x5.33	PT6003	10002761
K17 120-099	120	99	8.1	1.8	10.5	97.00x7	PT6003	10002766
K17 120-104.5	120	104.5	6.3	1.3	8	100.97x5.33	PT6003	10002769
K17 120-109	120	109	4.2	1	6	107.54x3.53	PT6003	10002771
K17 125-104	125	104	8.1	1.8	10.5	102.00x6.99	PT6003	10002775
K17 125-109.5	125	109.5	6.3	1.3	8	107.32x5.33	PT6003	10002777
K17 125-114	125	114	4.2	1	6	110.72x3.53	PT6003	10002780
K17 127- 111.50	127	111.5	6.3	1.3	8	109.54x5.33	PT6003	10002784
K17 130-109	130	109	8.1	1.8	10.5	107.00x6.99	PT6003	10002786
K17 130-114.5	130	114.5	6.3	1.3	8	113.67x5.33	PT6003	10002788
K17 135-114	135	114	8.1	1.8	10.5	113.67x6.99	PT6003	10002791
K17 140-119	140	119	8.1	1.8	10.5	116.84x6.99	PT6003	10002796
K17 140-124.5	140	124.5	6.3	1.3	8	123.19x5.33	PT6003	10002798
K17 140-129	140	129	4.2	1	6	126.60x3.53	PT6003	10002800
K17 142-121	142	121	8.1	1.8	10.5	116.84x6.99	PT6003	10002802
K17 145-124	145	124	8.1	1.8	10.5	123.20x6.99	PT6003	10002803
K17 150-129	150	129	8.1	1.8	10.5	126.37x6.99	PT6003	10002807
K17 150-134.5	150	134.5	6.3	1.3	8	130.20x5.33	PT6003	10002810
K17 155-134	155	134	8.1	1.8	10.5	132.72x6.99	PT6003	10002817
K17 160-139	160	139	8.1	1.8	10.5	135.90x6.99	PT6003	10002822
K17 160-144.5	160	144.5	6.3	1.3	8	142.24x5.33	PT6003	10002825



	<b>D (H8)</b>	<b>d (h9)</b>	<b>L (+0.2/- 0)</b>	<b>r1</b>	<b>C</b>	<b>O-Ring</b>	<b>MATERIAL</b>	<b>Kastaş CODE</b>
K17 165-144	165	144	8.1	1.8	10.5	142.24x6.99	PT6003	10002829
K17 170-149	170	149	8.1	1.8	10.5	145.42X6.99	PT6003	10002834
K17 175-154	175	154	8.1	1.8	10.5	151.77x6.99	PT6003	10002838
K17 180-159	180	159	8.1	1.8	10.5	158.12x6.99	PT6003	10002841
K17 185-164	185	164	8.1	1.8	10.5	161.90X6. 99	PT6003	10002846
K17 185-169.5	185	169.5	6.3	1.3	8	164.47X5.33	PT6003	10002847
K17 190-169	190	169	8.1	1.8	10.5	168.30x6.99	PT6003	10002849
K17 195-174	195	174	8.1	1.8	10.5	170.82x6.99	PT6003	10002857
K17 195-179.5	195	179.5	6.3	1.3	8	177.17x5.33	PT6003	10002858
K17 200-179	200	179	8.1	1.8	10.5	177.17x6.99	PT6003	10002859
K17 200-184.5	200	184.5	6.3	1.3	8	183.52x5.33	PT6003	10002863
K17 205-184	205	184	8.1	1.8	10.5	183.52X6.99	PT6003	10002871
K17 210-189	210	189	8.1	1.8	10.5	187.3X6.99	PT6003	10002872
K17 215-194	215	194	8.1	1.8	10.5	189.87x6.99	PT6003	10002875
K17 220-199	220	199	8.1	1.8	10.5	196.22x6.99	PT6003	10002877
K17 225-204	225	204	8.1	1.8	10.5	202.57x6.99	PT6003	10002881
K17 230-209	230	209	8.1	1.8	10.5	202.57x6.99	PT6003	10002887
K17 240-219	240	219	8.1	1.8	10.5	215.27X6.99	PT6003	10002891
K17 245-224	245	224	8.1	1.8	10.5	221.62X6.99	PT6003	10002894
K17 250-229	250	229	8.1	1.8	10.5	227.97X6. 99	PT6003	10002895
K17 254-233	254	233	8.1	1.8	10.5	227.97X6.99	PT6003	10002900
K17 255-234	255	234	8.1	1.8	10.5	227.97X6. 99	PT6003	10002901
K17 260-239	260	239	8.1	1.8	10.5	234.32X6.99	PT6003	10002904
K17 265-244	265	244	8.1	1.8	10.5	240.67X6.99	PT6003	10002906
K17 270-249	270	249	8.1	1.8	10.5	247.00x6.99	PT6003	10002907
K17 275-254	275	254	8.1	1.8	10.5	247.00x6.99	PT6003	10002910
K17 280-259	280	259	8.1	1.8	10.5	253.57x6.99	PT6003	10002913
K17 290-269	290	269	8.1	1.8	10.5	266.07x6.99	PT6003	10002919
K17 300-275.5	300	275.5	8.1	1.8	12	272.40x6.99	PT6003	10002922
K17 300-279	300	279	8.1	1.8	10.5	278.77x6.99	PT6003	10002923
K17 305-284	305	284	8.1	1.8	10.5	278.77x6.99	PT6003	10002927
K17 310-289	310	289	8.1	1.8	10.5	285.1x6.99	PT6003	10002930
K17 315-294	315	294	8.1	1.8	10.5	291.47x6.99	PT6003	10002935
K17 320-295.5	320	295.5	8.1	1.8	12	291.47x6.99	PT6003	10002936

	<b>D (H8)</b>	<b>d (h9)</b>	<b>L (+0.2/- 0)</b>	<b>r1</b>	<b>C</b>	<b>O-Ring</b>	<b>MATERIAL</b>	<b>Kastaş CODE</b>
K17 320-299	320	299	8.1	1.8	10.5	297.88x6.99	PT6003	10002937
K17 325-300.5	325	300.5	8.1	1.8	12	297.88x6.99	PT6003	10002939
K17 325-304	325	304	8.1	1.8	10.5	297.88x6.99	PT6003	10002940
K17 330-305.5	330	305.5	8.1	1.8	12	304.17x6.99	PT6003	10002942
K17 340-315.5	340	315.5	8.1	1.8	12	310.50x6.99	PT6003	10002947
K17 350-325.5	350	325.5	8.1	1.8	12	323.20x6.99	PT6003	10002951
K17 360-335.5	360	335.5	8.1	1.8	12	329.57x6.99	PT6003	10002959
K17 365-340.5	365	340.5	8.1	1.8	12	335.90x6.99	PT6003	10002961
K17 370-345.5	370	345.5	8.1	1.8	12	342.27x6.99	PT6003	10002962
K17 375-350.5	375	350.5	8.1	1.8	12	342.27X6.99	PT6003	10002963
K17 380-355.5	380	355.5	8.1	1.8	12	354.90x6.99	PT6003	10002964
K17 390-365.5	390	365.5	8.1	1.8	12	354.90x6.99	PT6003	10002967
K17 400-375.5	400	375.5	8.1	1.8	12	367.67x6.99	PT6003	10002970
K17 415-390.5	415	390.5	8.1	1.8	12	380.37x6.99	PT6003	10002984
K17 420-395.5	420	395.5	8.1	1.8	12	393.07x6.99	PT6003	10002985
K17 430-405.5	430	405.5	8.1	1.8	12	393.07x6.99	PT6003	10002987
K17 440-415.5	440	415.5	8.1	1.8	12	405.26x6.99	PT6003	10002990
K17 450-425.5	450	425.5	8.1	1.8	12	417.96x6.99	PT6003	10002992
K17 460-435.5	460	435.5	8.1	1.8	12	430.66x6.99	PT6003	10002997
K17 470-445.5	470	445.5	8.1	1.8	12	443.36x6.99	PT6003	10003000
K17 475-450.5	475	450.5	8.1	1.8	12	443.36x6.99	PT6003	10003001
K17 480-455.5	480	455.5	8.1	1.8	12	443.36x6.99	PT6003	10003002
K17 485-460.5	485	460.5	8.1	1.8	12	456.06x6.99	PT6003	10003004
K17 495-470.5	495	470.5	8.1	1.8	12	468.76x6.99	PT6003	10003006
K17 500-475.5	500	475.5	8.1	1.8	12	468.76x6.99	PT6003	10003007
K17 520-495.5	520	495.5	8.1	1.8	12	494.16x6.99	PT6003	10003009
K17 530-505.5	530	505.5	8.1	1.8	12	494.16x6.99	PT6003	10003011
K17 540-515.5	540	515.5	8.1	1.8	12	506.86x6.99	PT6003	10003012
K17 550-525.5	550	525.5	8.1	1.8	12	506.86x6.99	PT6003	10003014
K17 560-535.5	560	535.5	8.1	1.8	12	532.26x6.99	PT6003	10003015
K17 565-540.5	565	540.5	8.1	1.8	12	532.26x6.99	PT6003	10003016
K17 580-555.5	580	555.5	8.1	1.8	12	557.66x6.99	PT6003	10003018
K17 600-575.5	600	575.5	8.1	1.8	12	557.66x6.99	PT6003	10003019
K17 610-585.5	610	585.5	8.1	1.8	12	582.68x6.99	PT6003	10003020
K17 640-615.5	640	615.5	8.1	1.8	12	608.08x6.99	PT6003	10003025
K17 660-635.5	660	635.5	8.1	1.8	12	622.00x6.99	PT6003	10003027

**Алматы** (7273)495-231  
**Ангарск** (3955)60-70-56  
**Архангельск** (8182)63-90-72  
**Астрахань** (8512)99-46-04  
**Барнаул** (3852)73-04-60  
**Белгород** (4722)40-23-64  
**Благовещенск** (4162)22-76-07  
**Брянск** (4832)59-03-52  
**Владивосток** (423)249-28-31  
**Владикавказ** (8672)28-90-48  
**Владимир** (4922)49-43-18  
**Волгоград** (844)278-03-48  
**Вологда** (8172)26-41-59  
**Воронеж** (473)204-51-73  
**Екатеринбург** (343)384-55-89

**Иваново** (4932)77-34-06  
**Ижевск** (3412)26-03-58  
**Иркутск** (395)279-98-46  
**Казань** (843)206-01-48  
**Калининград** (4012)72-03-81  
**Калуга** (4842)92-23-67  
**Кемерово** (3842)65-04-62  
**Киров** (8332)68-02-04  
**Коломна** (4966)23-41-49  
**Кострома** (4942)77-07-48  
**Краснодар** (861)203-40-90  
**Красноярск** (391)204-63-61  
**Курск** (4712)77-13-04  
**Курган** (352)50-90-47  
**Липецк** (4742)52-20-81

**Магнитогорск** (3519)55-03-13  
**Москва** (495)268-04-70  
**Мурманск** (8152)59-64-93  
**Набережные Челны** (8552)20-53-41  
**Нижний Новгород** (831)429-08-12  
**Новокузнецк** (3843)20-46-81  
**Ноябрьск** (3496)41-32-12  
**Новосибирск** (383)227-86-73  
**Омск** (3812)21-46-40  
**Орел** (4862)44-53-42  
**Оренбург** (3532)37-68-04  
**Пенза** (8412)22-31-16  
**Петрозаводск** (8142)55-98-37  
**Псков** (8112)59-10-37  
**Пермь** (342)205-81-47

**Ростов-на-Дону** (863)308-18-15  
**Рязань** (4912)46-61-64  
**Самара** (846)206-03-16  
**Санкт-Петербург** (812)309-46-40  
**Саратов** (845)249-38-78  
**Севастополь** (8692)22-31-93  
**Саранск** (8342)22-96-24  
**Симферополь** (3652)67-13-56  
**Смоленск** (4812)29-41-54  
**Сочи** (862)225-72-31  
**Ставрополь** (8652)20-65-13  
**Сургут** (3462)77-98-35  
**Сыктывкар** (8212)25-95-17  
**Тамбов** (4752)50-40-97  
**Тверь** (4822)63-31-35

**Тольятти** (8482)63-91-07  
**Томск** (3822)98-41-53  
**Тула** (4872)33-79-87  
**Тюмень** (3452)66-21-18  
**Ульяновск** (8422)24-23-59  
**Улан-Удэ** (3012)59-97-51  
**Уфа** (347)229-48-12  
**Хабаровск** (4212)92-98-04  
**Чебоксары** (8352)28-53-07  
**Челябинск** (351)202-03-61  
**Череповец** (8202)49-02-64  
**Чита** (3022)38-34-83  
**Якутск** (4112)23-90-97  
**Ярославль** (4852)69-52-93

**Россия** +7(495)268-04-70

**Казахстан** +7(7172)727-132

**Киргизия** +996(312)96-26-47

<https://kastas.nt-rt.ru/> || [ksi@nt-rt.ru](mailto:ksi@nt-rt.ru)